

# SEAFDEC TRAINING DEPARTMENT

SOUTHEAST ASIAN FISHERIES DEVELOPMENT CENTER

TD/RES/35

June 1994

## OBSERVATION REPORT ON COASTAL FISHING OPERATIONS IN JAPAN

25 March - 10 April 1993

by  
Worawit Wanchana

Research Paper Series No. 35

June 1994



OBSERVATION REPORT ON  
COASTAL FISHING OPERATIONS IN JAPAN  
25 March - 10 April 1993

by

Worawit Wanchana

Training Department  
Southeast Asian Fisheries Development Center



## CONTENTS

	Page
Shrimp and crab basket .....	1
One boat purse seine .....	15
Kamakura middle-scale set net .....	30
Beam trawl .....	47
Conger eel pot .....	59
References .....	66

## Acknowledgement

I would like to express my thanks to the following staff for their kind and valuable assistance.

Managing Director of KIFTC	Mr. Yasuhiko Saeki
Training officers & trainers	Mr. Naraiki Mikuni
	Mr. Motostugu Nitta
	Mr. Kasuhiro Takanashi
	Mr. Ritsuo Morimitsu
	Mr. Motoki Jujii

Thanks, also due to KIFTC staff and JICA for providing all the programmes.

April 1993



## Shrimp and crab basket fishing

- Date of practice** : 25-26 March
- Fishing port** : Bunba
- Fishing boat** : Idoenkyo-maru (15 tons, 650 ps)
- Fishing equipment** :
- 1) Portable side roller
  - 2) Hasami type hydraulic hauler (5 tons, 40 meter/minute) (see Fig. 9)
  - 3) Hydraulic roller
  - 4) Subhydraulic roller
  - 5) Remote controller and
  - 6) Stern hydraulic roller for crab pot fishing operation.
- Number of fishermen** : Three persons (one captain and two crew)
- Fishing gear construction:** (see Fig. 1-2)

The gear consists of basket, buoy line with chain, main line and branch line. Length of the buoy line is approximately 1.5 times the depth and interval between each basket depending on the length of the boat and speed capacity of the hydraulic rollers. (see Fig. 1-2)

### Fishing ground

The fishing ground is located in the continental shelf area of Sakami Bay and Tokyo Bay at a depth range of 150-1,000 meters. (see Fig. 3)

- Akasa shrimp (*Nephrops japonicus*) 200-250 m\*
- Botan shrimp (*Pandalus nipponensis*) 300-400 m\*
- Ibara crab (*Lithodes aequispina*) 550-650 m\*
- Esoibara crab (*Paralomis multispina*) 650-1,000 m\*

### Fishing method

#### 1. Bait

- a) Shrimp basket : One or two pieces of sardine is put in the bait container (stainless steel, Hi-sex, or Synthetic net, depending on the waiting time in the sea)
- b) Crab basket : Two pieces of yellow tail tuna and sardine head which are put in separate bait containers. (See Fig. 4)

2. Hauling : There are two types of pot fishing gear, with or without buoy line, this is because in some areas such as Tokyo Bay, so buoy lines are a danger to travelling vessel. In the case of no buoy line, the hooking search line method is used for hauling the gear. (See Fig. 5)

In normal operations, the buoy line will be picked up and passed through a portable side roller and Hasami hauler, respectively. The portable side roller has a remote controller (see Fig. 7), so while the basket is being hauled, fishermen can change the bait coastline and their catch will be selected. (See Fig. 10). For shrimp basket fishing, the gear can be arranged on the fore deck but the crab basket fishing gear needs more space, so these are arranged on the stern deck.

---

\* Refers to "Deep sea crab & shrimp basket Fishery in Nagai", Mr. Motoki Fujii, KIFTC.



3. Shooting : The buoy is shot and followed by a float line which is attached by a chain, then each basket is thrown in one by one until one unit is finished. The waiting time is approximately one week.

### Discussion

The hauling, is influenced by speed, direction of wind, and current. By using a Hasami hydraulic hauler and portable side roller, they can haul the baskets from both sides of the boat. (See Fig. 8). For the costs expenses and price of the catch, see Table 1-2. Deep sea pot fishing is not influenced by season, weather conditions, or conflict with other types of fishing gears and the amount of catch is easy to control.

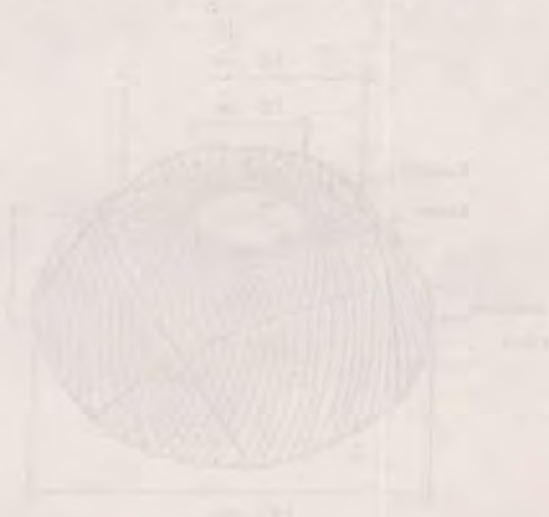

FIG. 8. Diagram of floating gear construction.

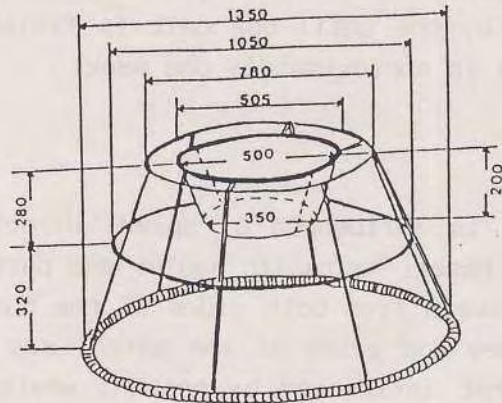

Fig. 1 Crab pot fishing gear construction.

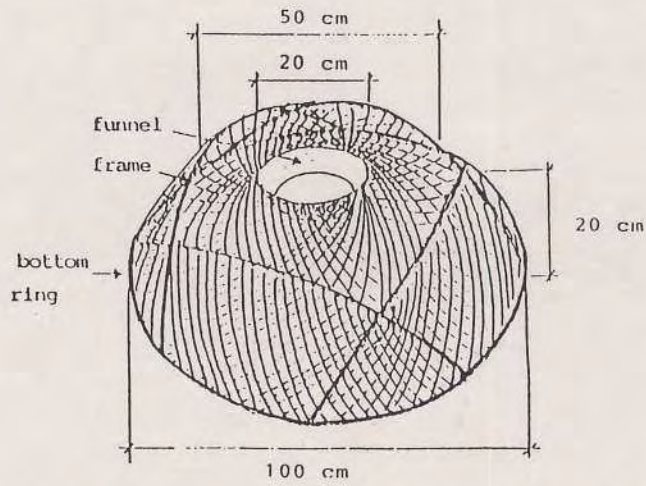

Fig. 2 Shrimp pot fishing gear construction.



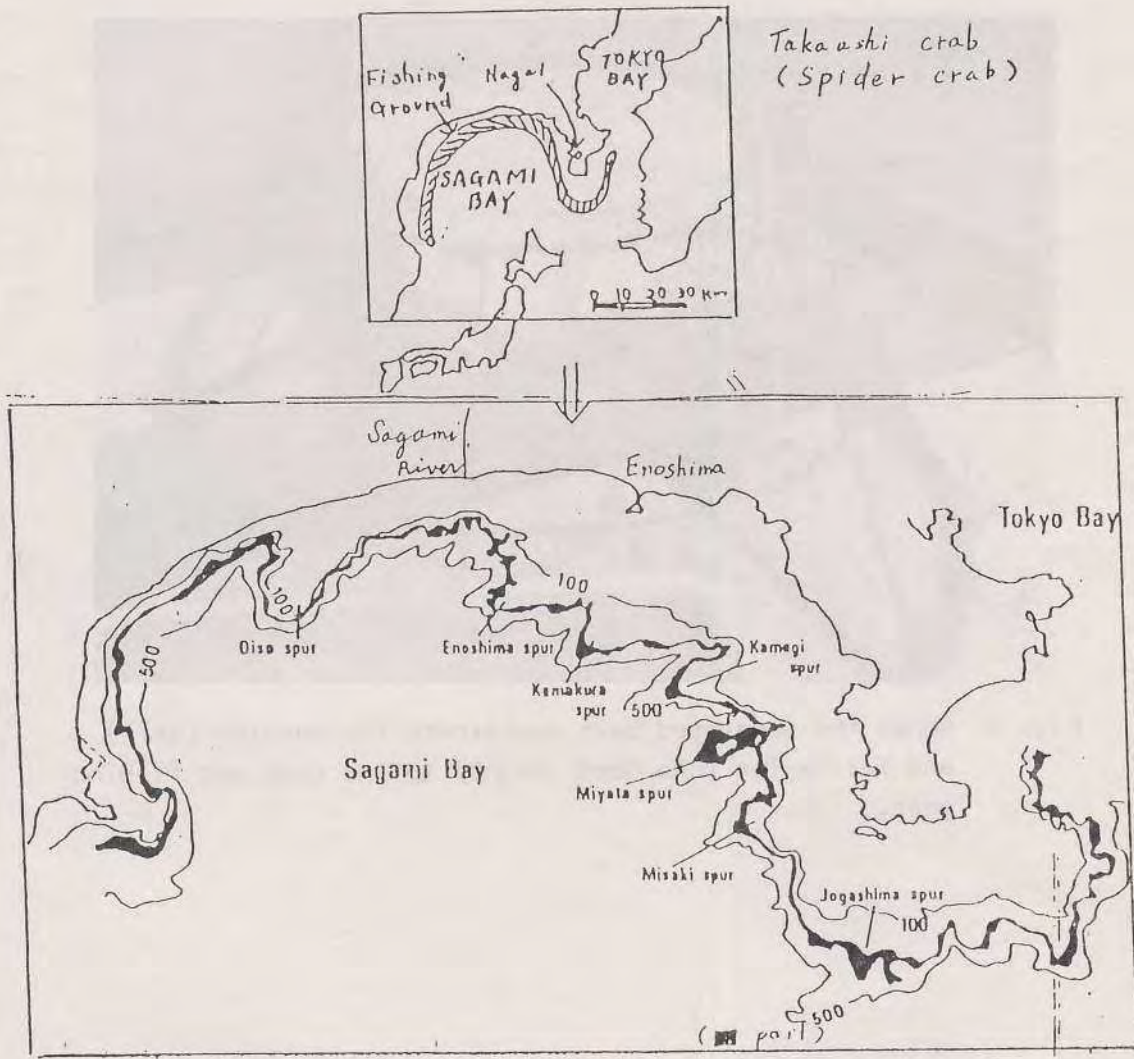

Fig. 3 Fishing ground for Akasa shrimp.



Fig. 4 Shows the separated bait containers for Sardine (left) and Yellow fin tuna head (right) in the crab pot fishing gear.



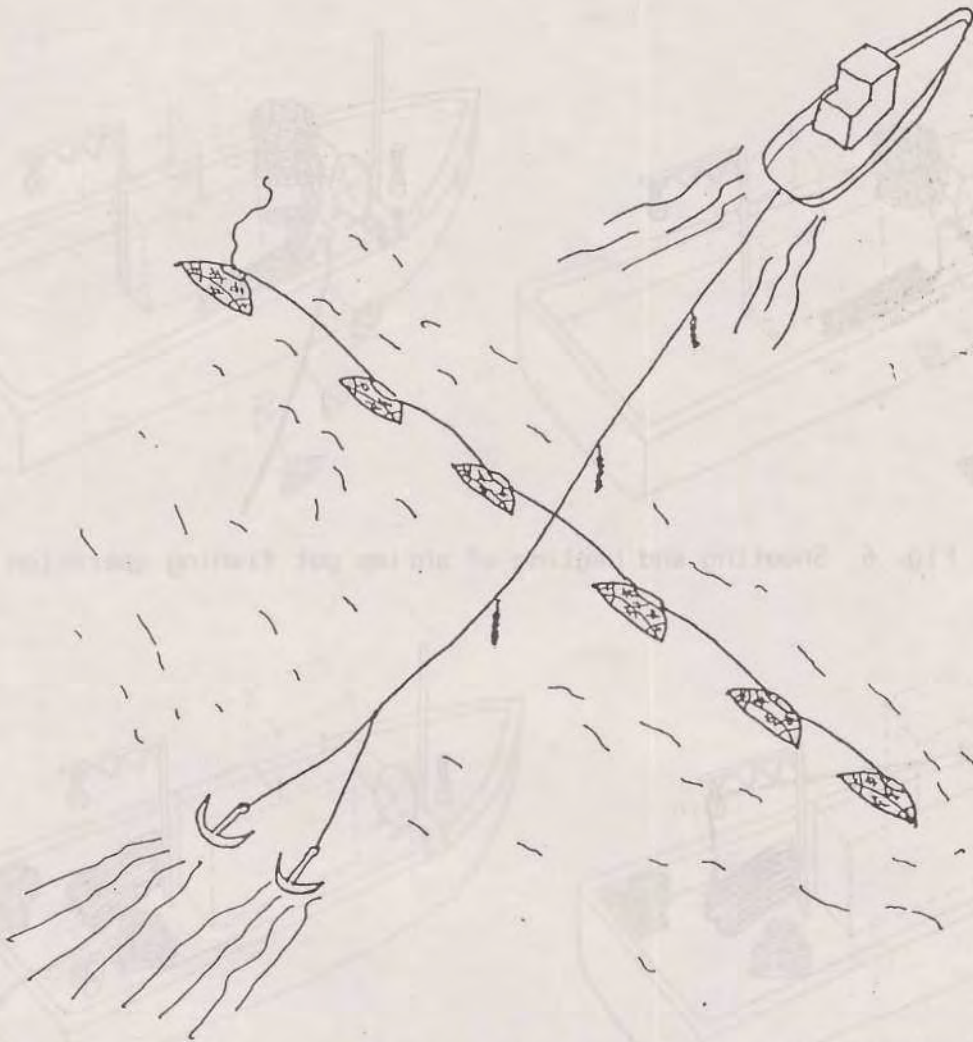

Fig. 5 Hooking search line method for hauling the non-float line unit.

1. Portable Side Roller  
2. Hydraulic Hoist (see Hydraulic Hoist Section)  
3. Hydraulic Hoist  
4. Hydraulic Hoist  
5. Hydraulic Hoist  
6. Hydraulic Hoist

Fig. 7 - Search line and hauling of non-float line unit.

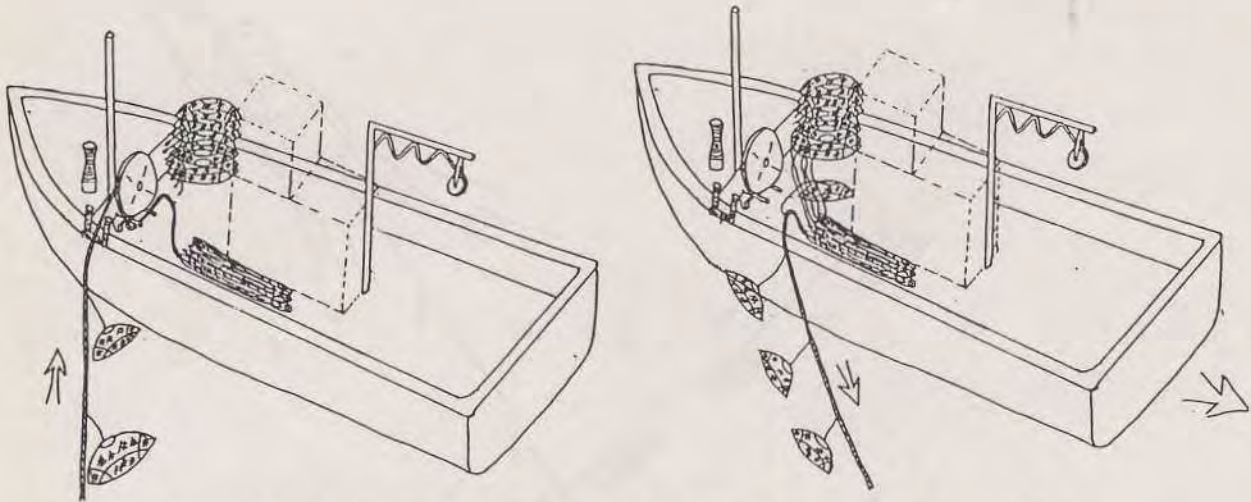
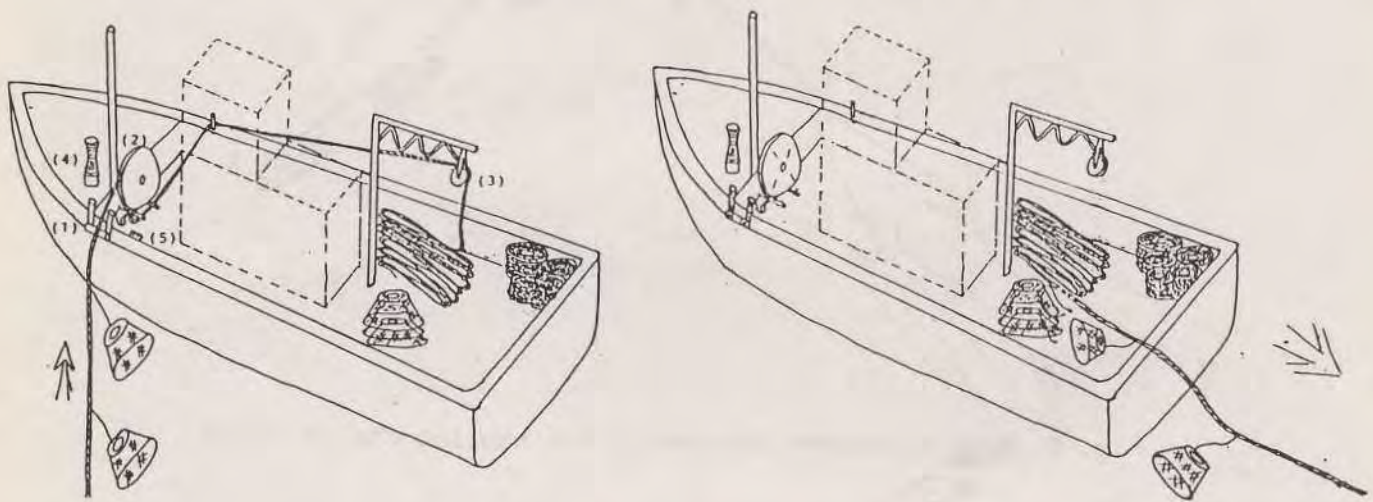

Fig. 6 Shooting and hauling of shrimp pot fishing operation



- (1) Portable Side Roller
- (2) Hasami type Hydraulic Hauler (5 ton.)
- (3) Hydraulic Roller
- (4) Sub Hydraulic Hauler
- (5) Remote Controller

Fig. 7 Shooting and hauling of crab pot fishing operation.



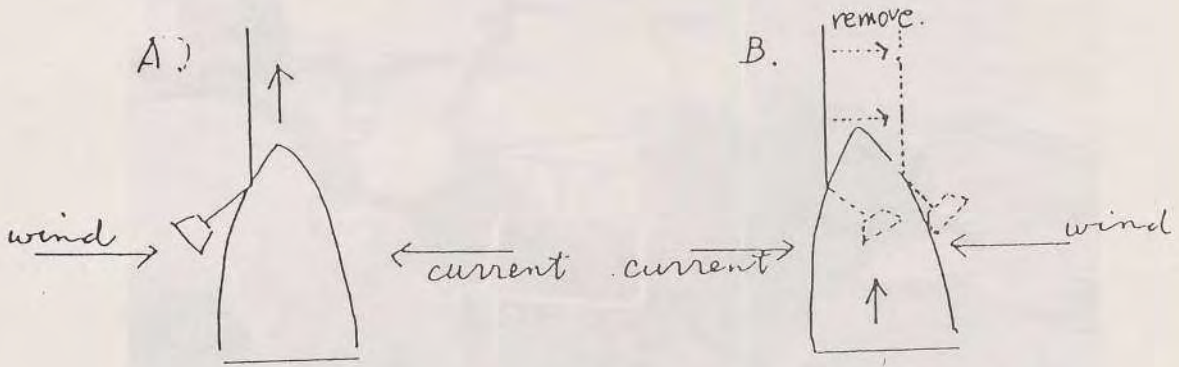

Fig. 8 The influence of current and wind during hauling operation.

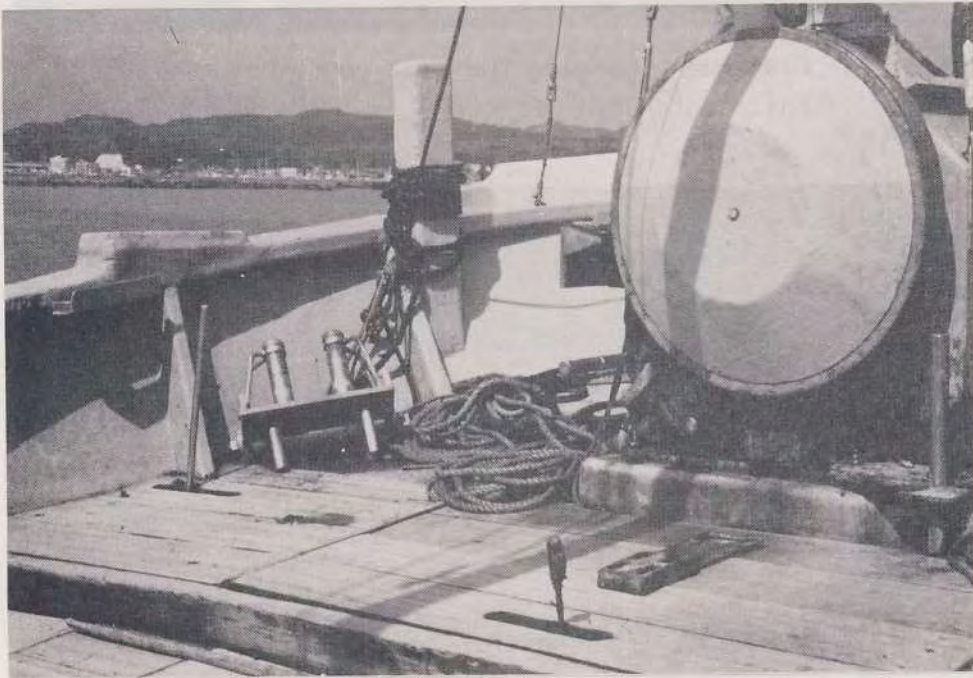

Fig. 9 Hasami type hydraulic hauler.



Fig. 10 Fishermen changing the bait container and selecting their catch.



Fig. 11 Market size of captured Akasa shrimp (they released the non-market size back to the sea).



**Appendix 1** Construction and bending method for shrimp pot bottom frame.

**Bottom frame;**

- Material : Iron rod (8 mm), wrapped by Vinyl tape (Red color)
- Diameter : 100 cm
- of ring
- Weight : 1.5 kg (Bottom frame works as sinker)



39cm Attaching Bamboo at equal intervals

**Top frame;**

- Material : Bamboo
- Length : 117 cm
- Width : 23 mm
- Thickness: 5 mm

**Bending method**

1. Fresh bamboo (green) must be used.
2. Split the bamboo vertically at appropriate widths.
3. Don't remove surface skin of bamboo.
4. Bend a piece of split bamboo heating its back with fire.
5. Put into water to cool immediately after bending.
6. Cut the edge of the bamboo piece as figure shows.

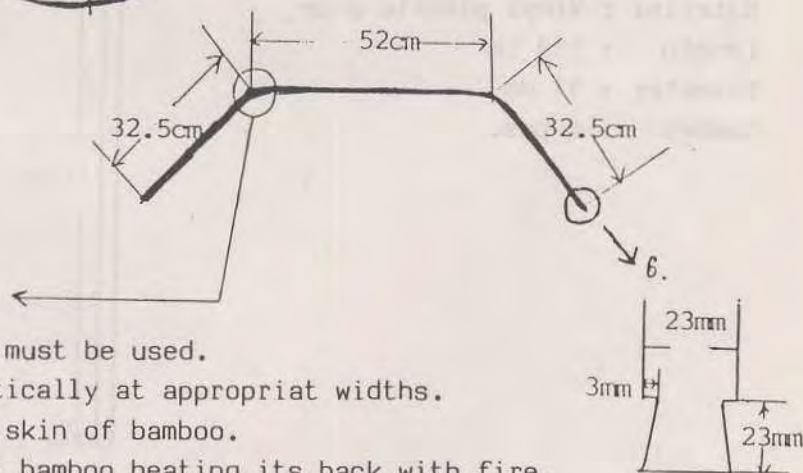

**Appendix 2** Construction of shrimp pot bottom frame (latest type).

Bottom frame;

Material : Plastic coated steel ring (8 mm, red color) with support rods (L:8 cm)

Diameter : 100 cm  
of ring

Weight : 1.8 kg (Bottom frame works as sinker)

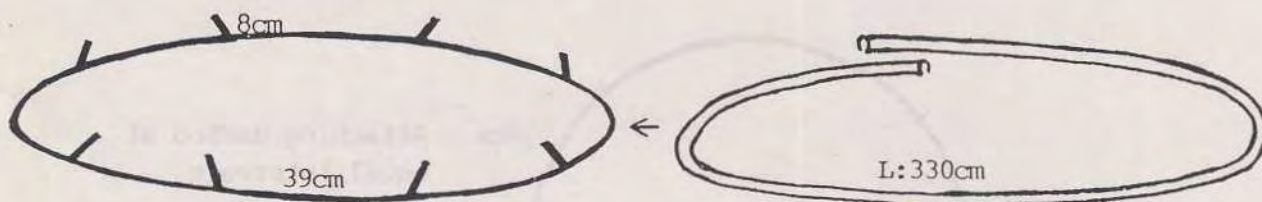

Attach plastic ring-cover (red color)  
for reinforcement last

Top frame;

Material : Vinyl plastic pipe

Length : 113 cm

Diameter : 17 mm

Number : 4 pcs.

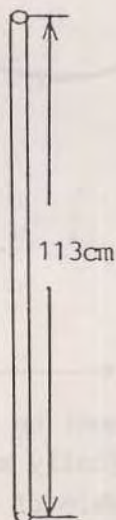



**Appendix 3** Construction of net and funnel materials for shrimp pot gear.

Net

Material : Polyester (Tetron)  
 knotless, 18

Mesh size : 25.3 mm

Color : Red

Number of Mesh: 145 x 49 (L. x D.)

Funnel

Material : Plastic

Color : Red

Top dia. : 22 cm

Bottom dia.: 16 cm

Depth : 8 cm

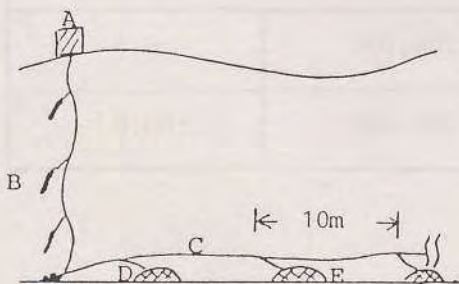
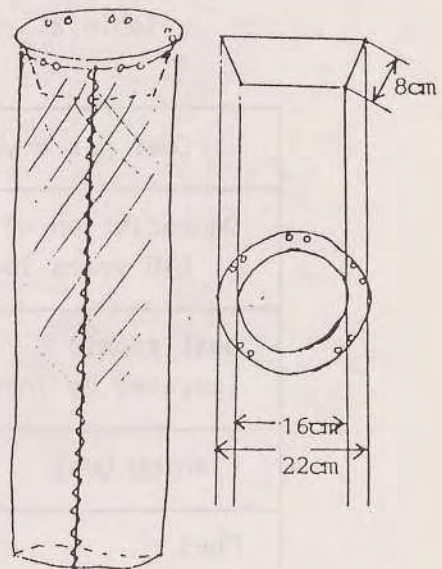
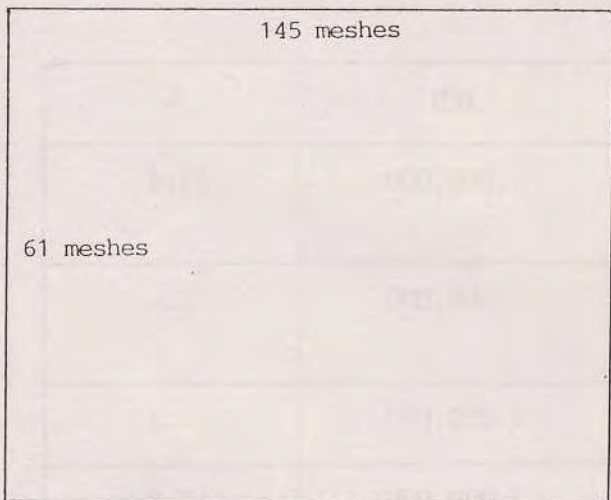

- A. Buoy : Styro-foam
- B. Chain : Total 20kg
- C. Main line : P.P. 16mm
- D. Branch line : P.P. 6-8mm
- E. Basket : 80-150pcs.

Table 1. Price and amount of shrimp and crab

	Price (average)	Amount/day
Shrimp	Y 4,000 - Y 10,000 (Y 6,000)	8 - 20 kg (10 kg)
Crab	Y 1,500 - Y 2,800	20 - 80 kg (40 kg)

in 1988

Table 2. Cost of expenses

Cost per a year	YEN	%
Depreciation of boat (10 years loan)	5,000,000	21.6
Boat repair (covered by insurance)	600,000	2.6
Fishing gear	1,000,000	4.3
Fuel	3,000,000	13.0
Personal (3 persons)	12,000,000	52.0
Bait & ice	1,500,000	6.5
Total	23,100,000	100.0



### One boat purse seine fishing

- Date of practice** : 29 March
- Fishing port** : Sashima
- Fishing boat** : Tensho-maru, this boat belongs to a fisheries cooperative which engages only in purse seine fishing. The fishery cooperative consists of six boats (three searching boats, two purse seiners and one mother boat) the total crew numbers 17 persons and there are two types of purse seiner:
- (i) Sardine purse seiner
  - (ii) Anchovy purse seiner
- Fishing equipment** : See Appendix. 1
- Number of fishermen** : Seven person/one purse seiner
- Fishing gear construction** : See Fig. 1

From experience, the fishermen instead of attaching the bridle rope and purse ring directly to the sinker line, attach it to the middle of the bottom selvedge net to prevent the sinker line getting stuck on the bottom (see Fig. 3). Also, they use a sea anchor "Parasol<sup>on</sup> type" instead of skiff boat because it's easier to operate. (See Fig. 2).

- Fishing ground** : On the observation day, a fishing operation was carried out in the area of 30 meter depth (mud bottom) near Sashima port.

1982, March  
SAILING NET - SHIMIZU BOAT  
KAWASAKI, JAPAN

ONE BOAT TYPE (196/7) SHIMIZU PURSE SEINE NET

Floater:  
Number of Floater: 1000/m x 731.6m = 2,197 pcs.  
Buoyancy: 1,500g/pc.  
Total Buoyancy: 3,292.5kg

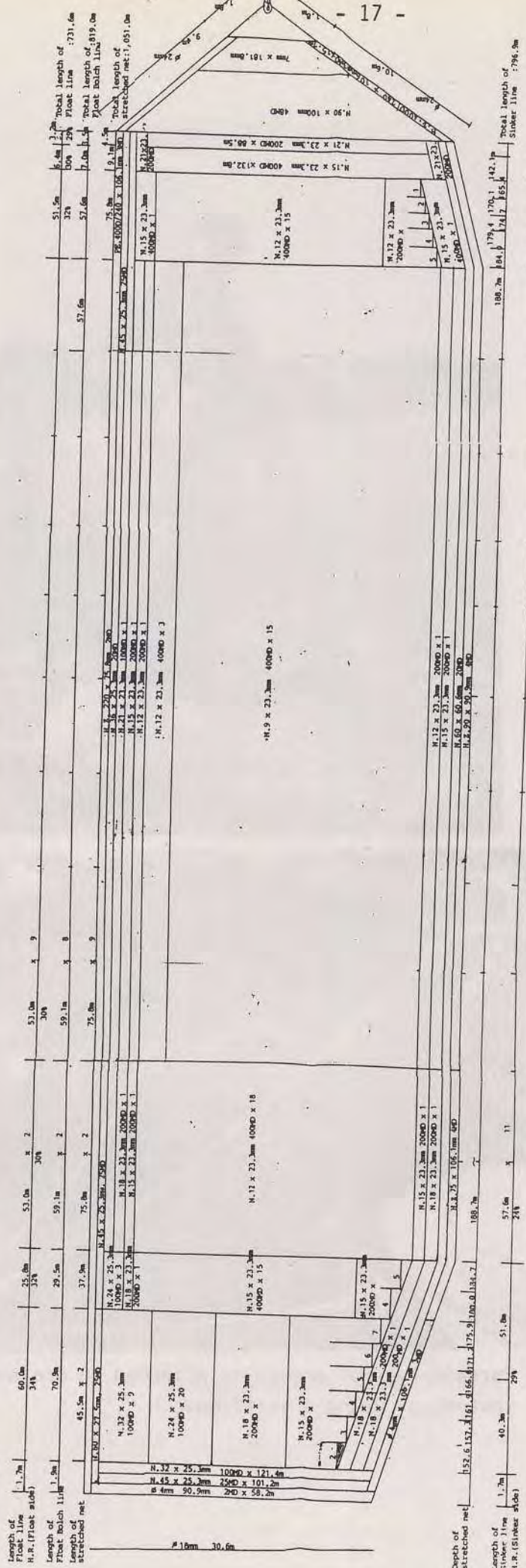

Length of float line H.R. (float side)	1.7m	60.0m	53.0m	x 2	51.0m	x 9	30%	Total length of float line	731.6m		
Length of float line H.R. (float side)	1.0m	70.0m	29.5m	x 2	59.1m	x 8		Total length of float line	731.6m		
Length of float line H.R. (float side)	1.0m	45.5m	37.9m	x 2	75.0m	x 9		Total length of float line	731.6m		
Length of stretched net	133.6	137.4	161.4	166.4	171.4	175.9	180.0	184.7	Total length of stretched net	1,051.0m	
Length of sinker line H.R. (sinker side)	1.7m	40.3m	29%	51.0m	57.6m	24%	188.7m	190.1	192.1	Total length of sinker line	796.5m
Weight of sinker	56.3g	56.3g	175	750g	275	56.3g	200	175g	200	Total weight of sinker	1,627.8kg
Weight of sinker	1,799g/m	2,46g/m	3,30g/m	2,46g/m	2,99g/m	1,30g/m	2,09g/m	1,30g/m	2,09g/m	Total weight of sinker	1,627.8kg
Weight of sinker	56.3g	56.3g	175	750g	275	56.3g	200	175g	200	Total weight of sinker	1,627.8kg
Weight of sinker	1,799g/m	2,46g/m	3,30g/m	2,46g/m	2,99g/m	1,30g/m	2,09g/m	1,30g/m	2,09g/m	Total weight of sinker	1,627.8kg

Fig.1 Fishing gear construction of one-boat type purse seine net.



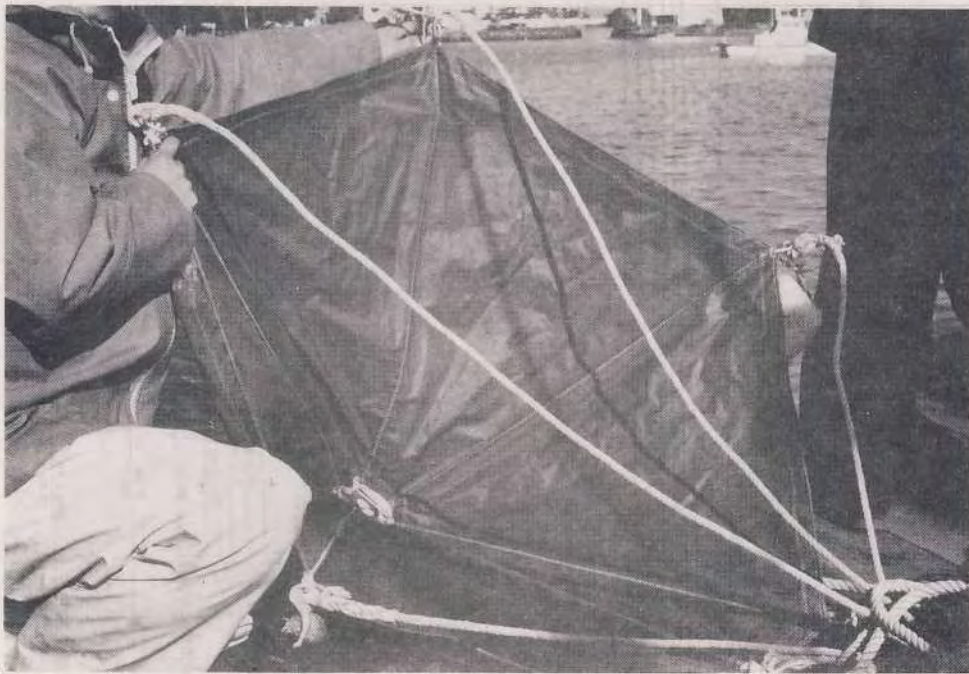

Fig. 2 Parasol-type of anchor is attached to one end of the net, instead of using a skiff boat.



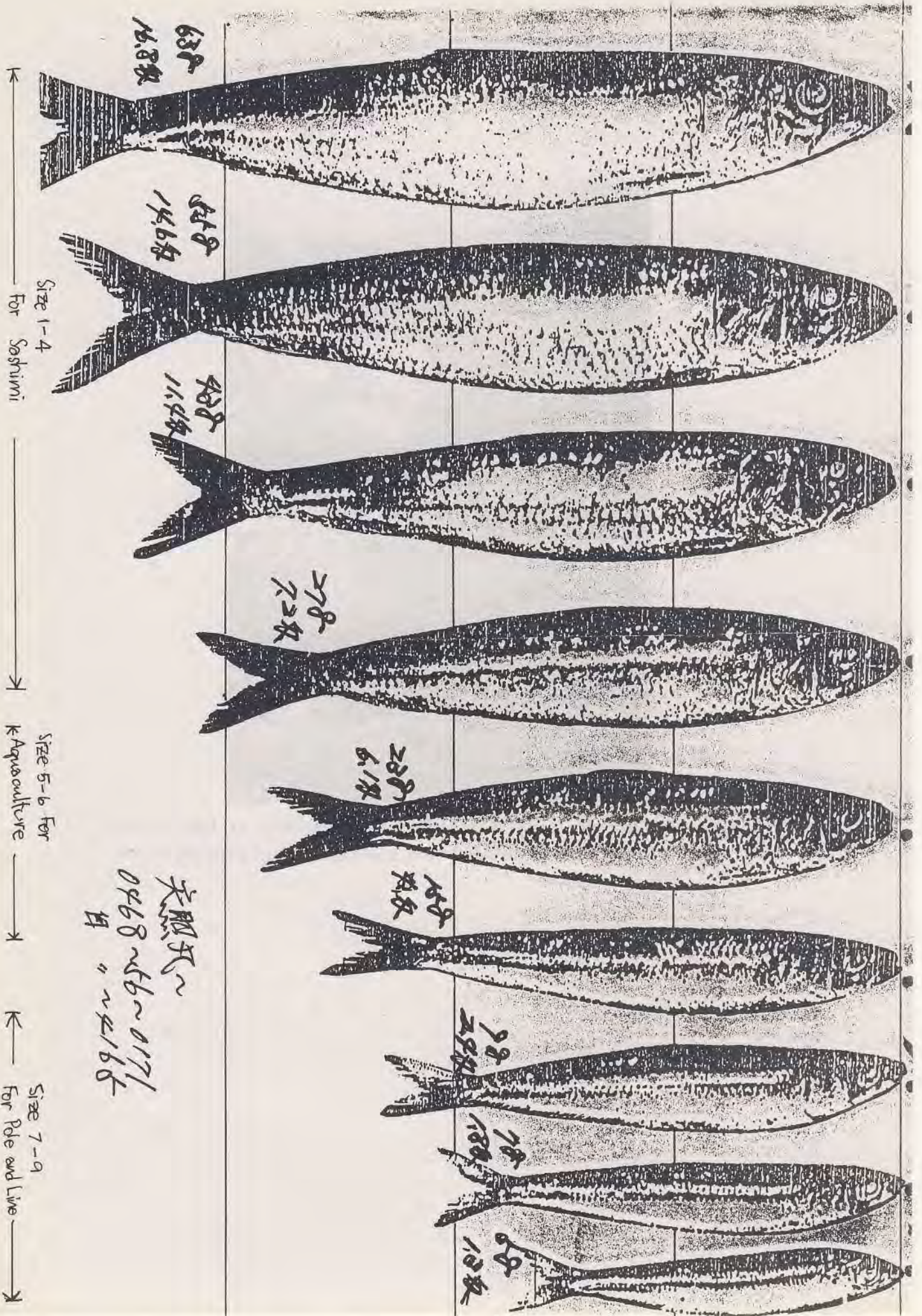

Fig. 3 The bridle rope is attached to the middle of the bottom selvedge net to prevent the sinker line getting stuck on the sea bottom.

Handwritten notes and diagrams on the right side of the page, including a vertical line with arrows and some illegible text.



Fig.4 The catch is separated for various kinds of demand.





Appendix. 1

1. Position of equipment on Purse Seiner

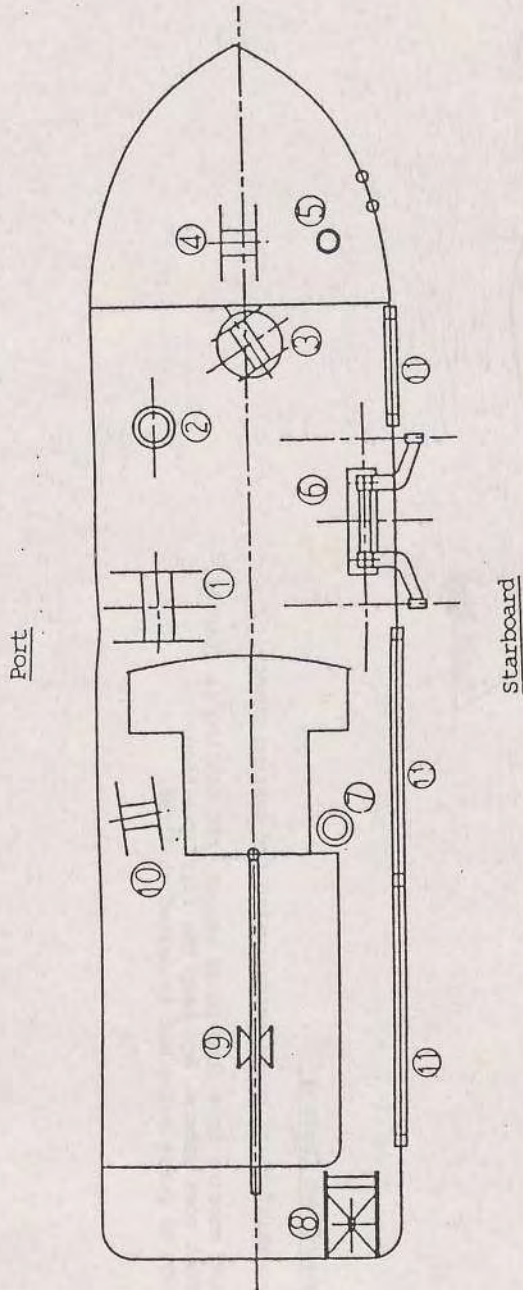

NO.	NAME
1	Pursing Winch
2	Pursing Capstan
3	Revolving Wire Reel
4	Winch (for tow line & mooring)
5	Roller
6	Adjusting Purse Davit
7	Starboard Capstan
8	Net Hauler
9	Net Shift Block
10	Choker Winch
11	Side Hauler



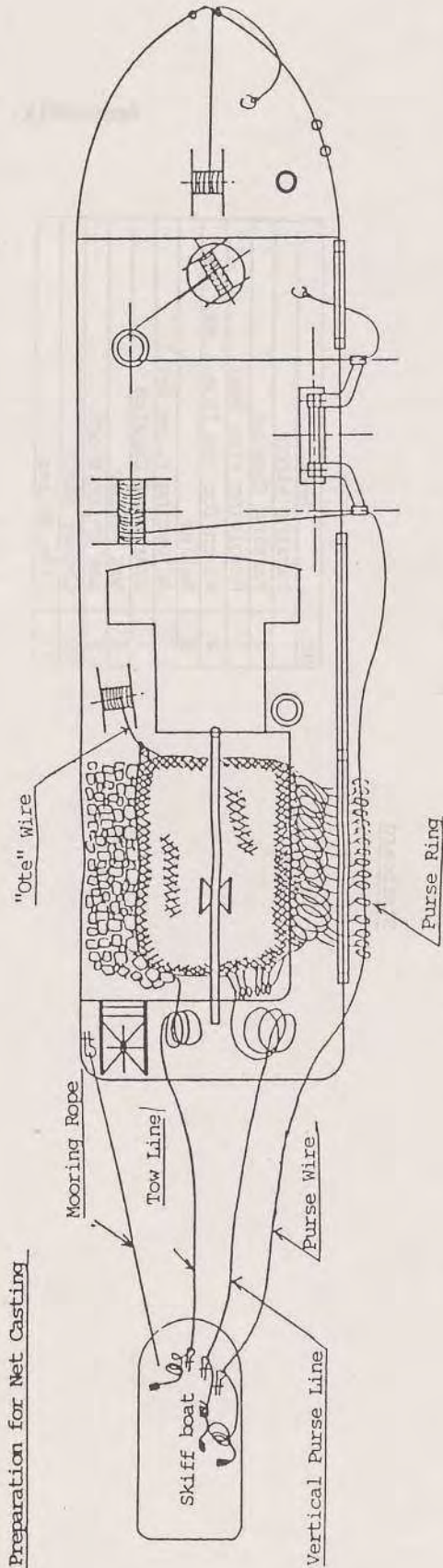

2. Preparation for Net Casting

3. Starting of Net Casting

1. Dragging skiff boat, purse seiner waits for casting chance.
2. Releasing mooring rope from purse seiner, net casting is started. Skiff boat goes astern, and keep the first position. Bunt side of purse seine net is casted at first.

Appendix. 3

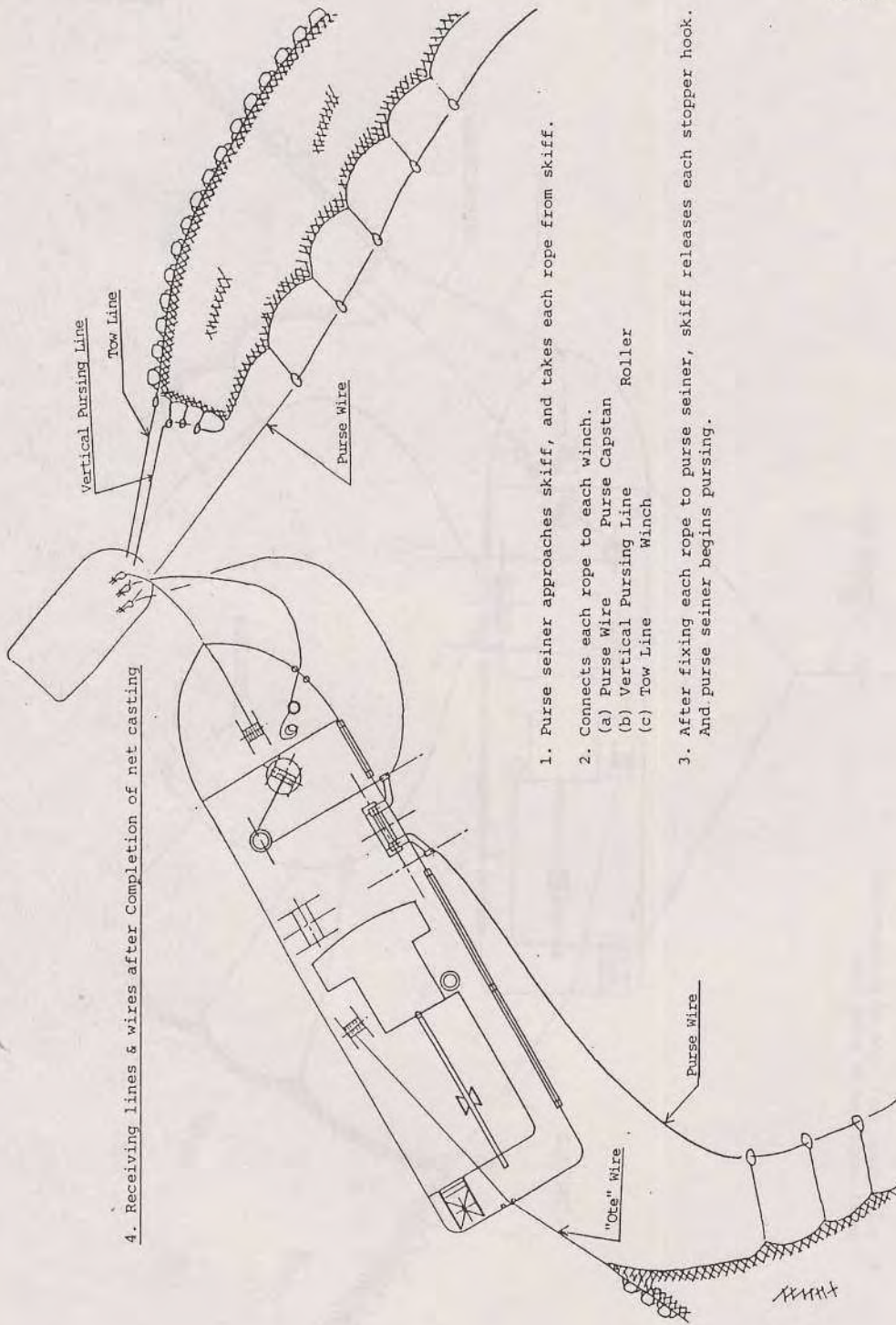

4. Receiving lines & wires after Completion of net casting

1. Purse seiner approaches skiff, and takes each rope from skiff.
2. Connects each rope to each winch.  
(a) Purse Wire      Purse Capstan  
(b) Vertical Pursing Line      Roller  
(c) Tow Line      Winch
3. After fixing each rope to purse seiner, skiff releases each stopper hook.  
And purse seiner begins pursing.



Appendix. 4

5. Pursing

1. Purse seiner rolls up each rope.
2. Skiff drags port side of purse seiner until completed to scoop fish.

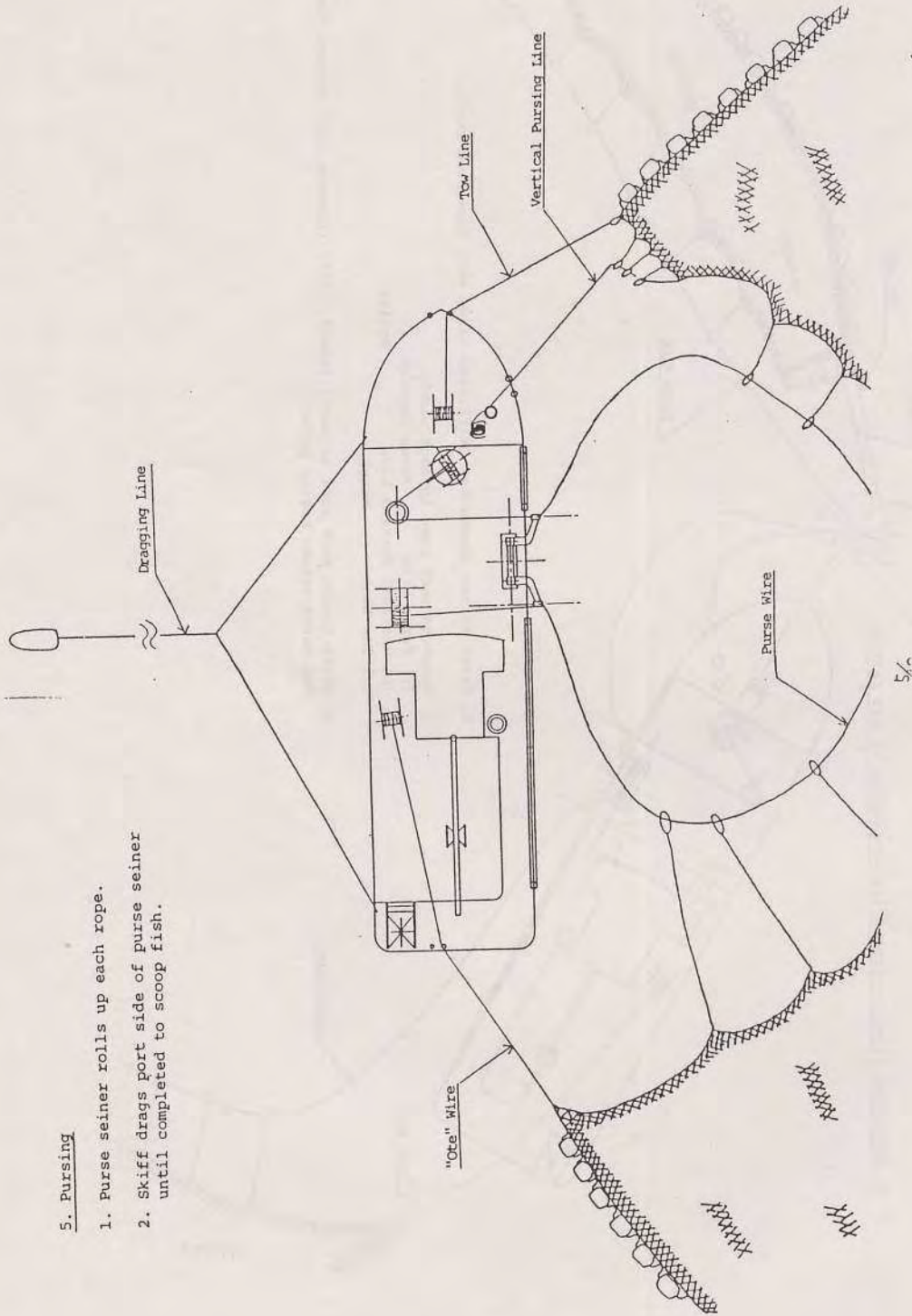

Appendix. 5

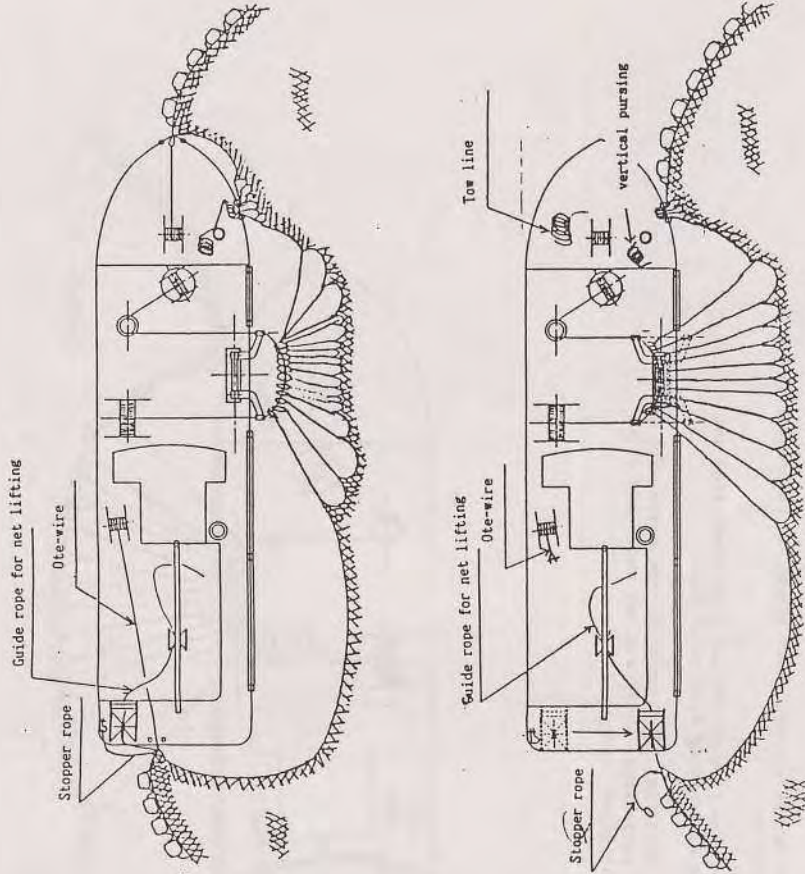

6. Start of net lifting after completed pursing

1. When purse rings are lifted up to the davit, the davit is returned to its former place.
2. The end of the tow line which has the bunt, is transferred to the sternboard side.
3. Stopper rope is connected to the end of ote-wire, and is kept by stopper hook.
4. Guide rope for net lifting is connected to ote-wire, through the net shift block and net hauler.
5. Ote-wire is removed from the edge of net.
6. Reeling up guide rope for net lifting, net hauler is transferred to the starboard side.
7. When the guide rope is stretched, net lifting is started by releasing the stopper hook.
8. Bunt is fixed by rope, and vertical pursing line is removed.
9. Tow line is taken off from the winch.



7. Net Lifting

1. The net, which is lifted by net hauler and net shift block, is rearranged in the net space for the next operation.
2. As net fitting progresses, the purse line is dragged from stern side and becomes taught, and purse rings are removed from purse line.
3. The purse line (without purse rings) is lifted into the net space with sinker line. The other set of purse rings which are set under the stern side hauler are attached to this purse line.

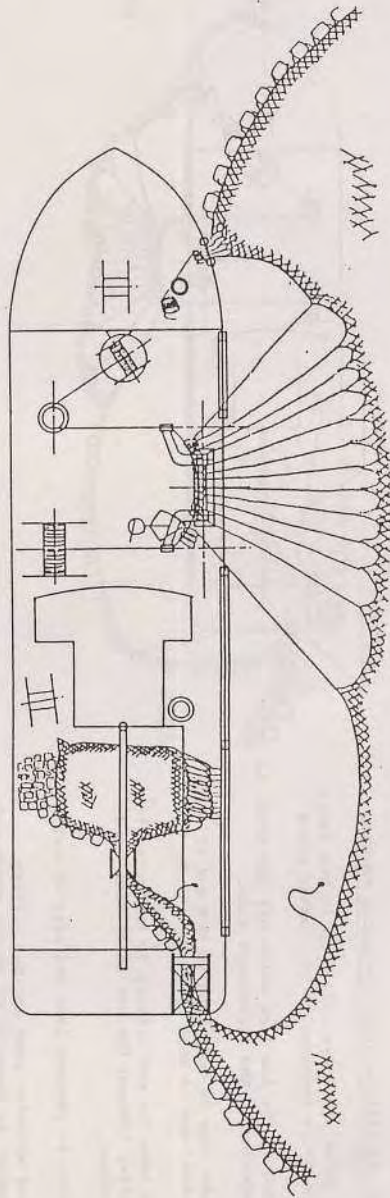

8. Preparation for scooping

1. Net lifting is stopped leaving suitable area of net for scooping. And the width of net area depends on the amount of fish.
2. Using side hauler, the sinker side of the net is lifted at first and then the float side of the net is also lifted on the deck.

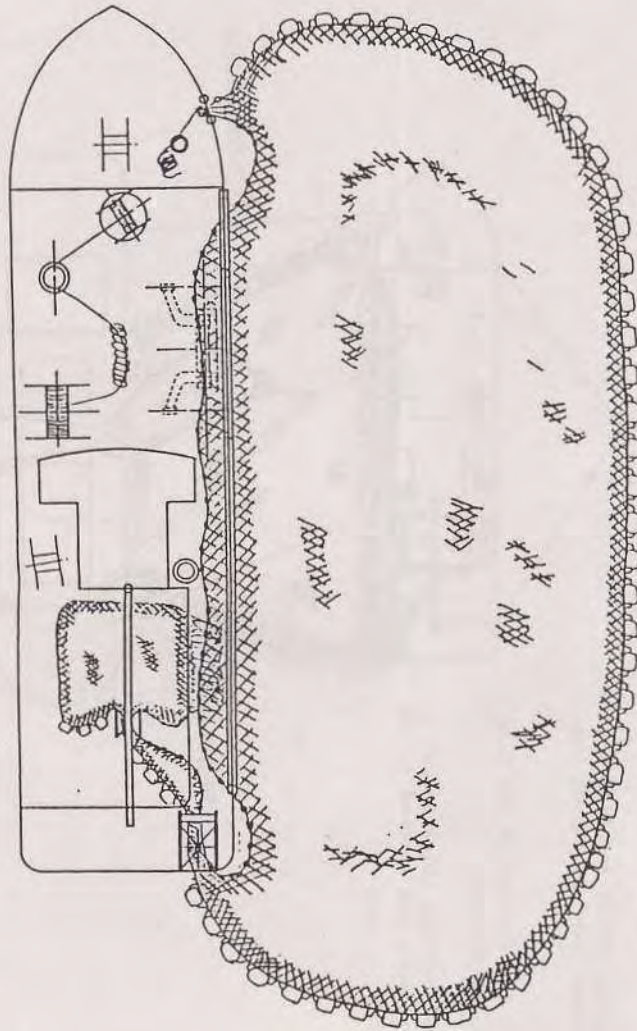



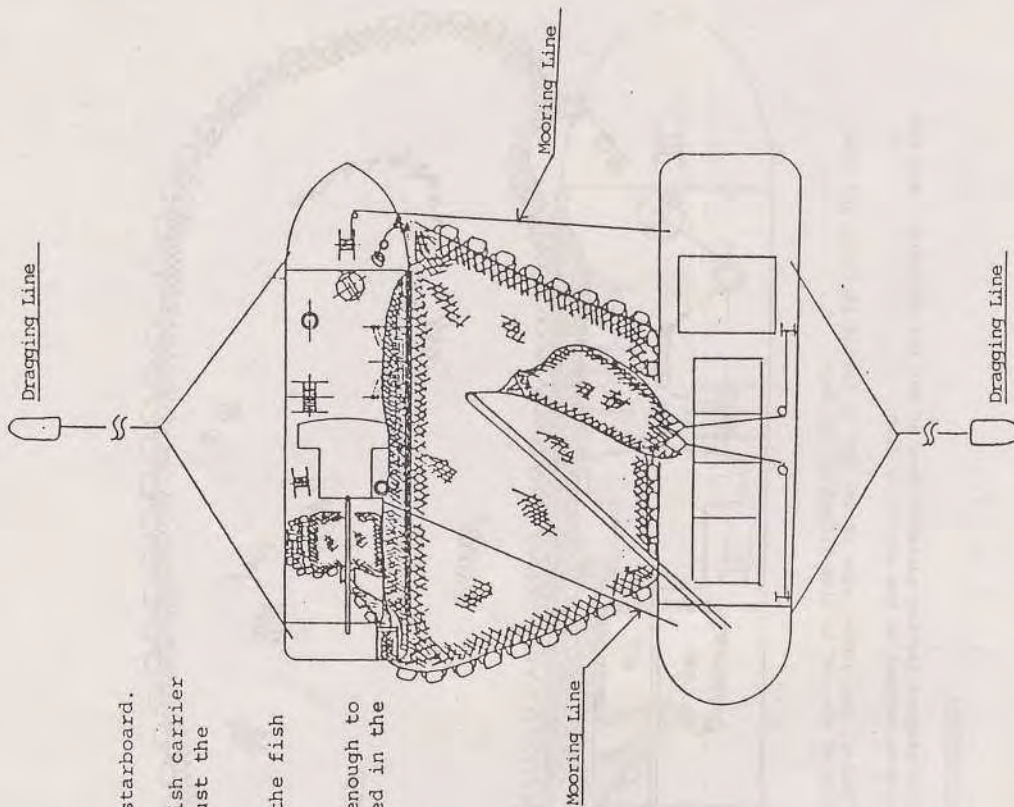

9. Fishing Scooping

1. Fish carrier boat hangs the float line at the starboard.
2. As the small boats drag the purse seiner and fish carrier to the port side, these boats can keep and adjust the position by mooring rope.
3. Net lifting is continued until the density of the fish school becomes thick enough to be scooped.
4. When the density of fish school becomes thick enough to be scooped, all the fish are scooped and stocked in the fish carrier.

10. Preparation for the next operation

1. Purse seiner releases bunt, and reverses side hauler. On the other hand, fish carrier releases float side net except one part, and leaves the purse seiner. Because of this the net which is hung on each boat opens in the sea.
2. And the net is lifted up to the deck by net hauler, and is rearranged in the net space.
3. Purse wire which is reeled up by revolving purse reel, is transferred to the purse capstan. Purse rings are removed from purse wire, and set under the stern side hauler.
4. Tow line and vertical purse line are transferred to stern, and are fixed to the edge of bunt.
5. End of the tow line is connected to "Ote" wire.
6. Net hauler is transferred to port side.
7. Purse davit is set.

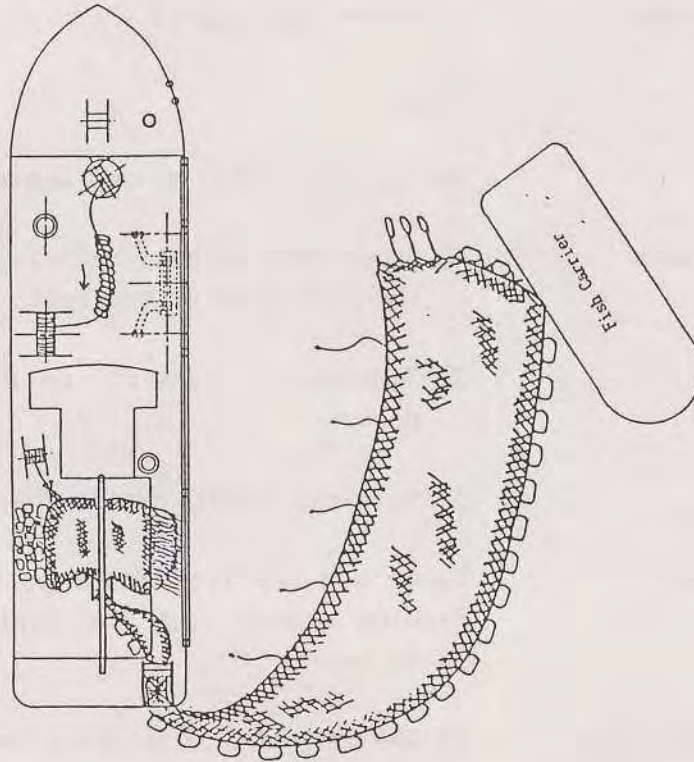



### Kamakura middle-scale set net fishing

- Date of practice** : 31 March and 1 April
- Fishing port** : Bunba
- Fishing boat** : Seiryō-maru (15.5 m) and assistant boat
- Fishing equipment** : 1) Three sets of ball rollers, installed on the port side of the boat.
- 2) Two sets of capstan, on stern and fore deck.
- 3) Vertical winch, beside the wheel house.
- Fishing ground** : Forty minutes from Bunba port to Kamakura fishing ground with the depth range from 25-40 meter.
- Fishing method** : 1) The main boat with installed ball roller stays at the end of first bag net (position a. in Appendix. 1), the assistant boat is at the entrance of funnel net (position b. in Appendix. 1).
- 2) The assistant boat starts to roll up the net, to close the entrance of the funnel net.
- 3) Winding rope and extension net are rolled up (see position c. and d. in appendix. 5).

- 4) First bag net are lifted up by using ball rollers, little by little so that the fish will be concentrated until they reach the entrance of the second bag net. At the same time, the winding rope is rolled up by using capstans.
- 5) The assistant boat moves to the cod end and the float line of the cod end net is lifted up.
- 6) The winding rope and nets continue to be lifted by the main boat, until they reach the cod end, then the fishermen will harvest the catch from the cod end by using the scoop net.

#### Discussion

Generally, the set net fishing grounds are selected according to the coastal isobar, existence and configuration of natural reefs, effects, of the tides on fish behaviour, and the physical characteristics of the sea. As well as the above considerations, an important factor is the determination of the configuration of the fish routes.

The materials utilized in the set net, can be used for at least 10 years, so that only some parts which are always passing the ball rollers will require changing or repairing within five years. This type of fishing gear has become more popular among the Japanese fishery, because of its long usability and good catch record.

The statistical data for Kamakura middle-scale set net are shown in appendix. 8-14.



Appendix. 1

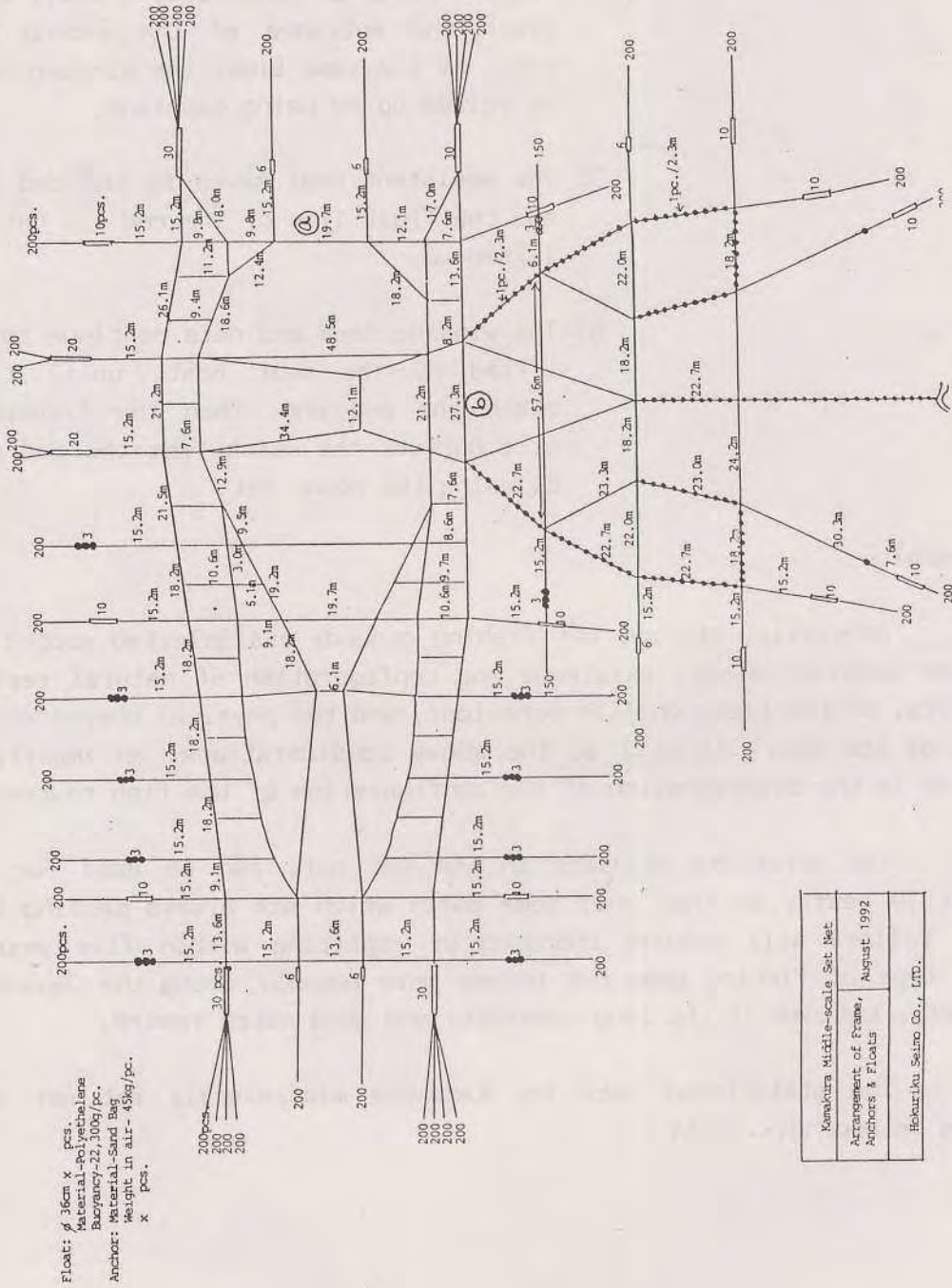

Float:  $\phi$  36cm X pcs.  
 Material-Polyethylene  
 Buoyancy-22,300g/pc.  
 Anchor: Material-Steel Bag  
 Weight in air-45kg/pc.  
 X pcs.

Kanakura Middle-scale Set Net	
Arrangement of Frame, Anchors & Floats	August 1992
Heikuriku Seino Co., LTD.	

Appendix. 2

Kamakura Middle-scale Set Net	
Arrangement of Frame, Anchors & Floats in Leader Net part	August 1992
Hokuriku Seimo Co., LTD.	

Float:  $\phi 36\text{cm}$  x pcs.  
 Material-Polyethelene  
 Buoyancy-22,300g/pc.  
 Anchor: Material-Sand Bag  
 Weight in air- 45kg/pc.  
 x pcs.

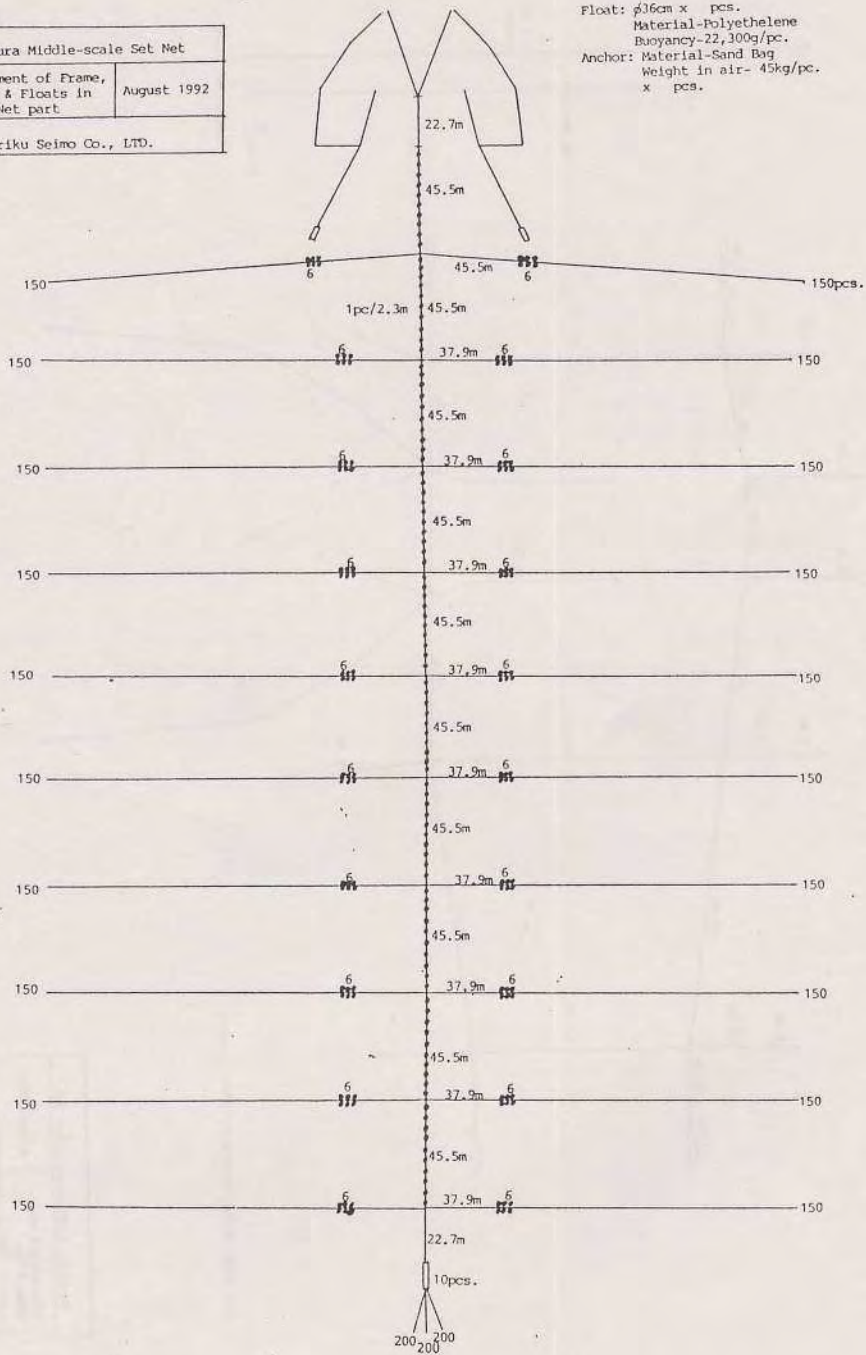









Appendix. 5

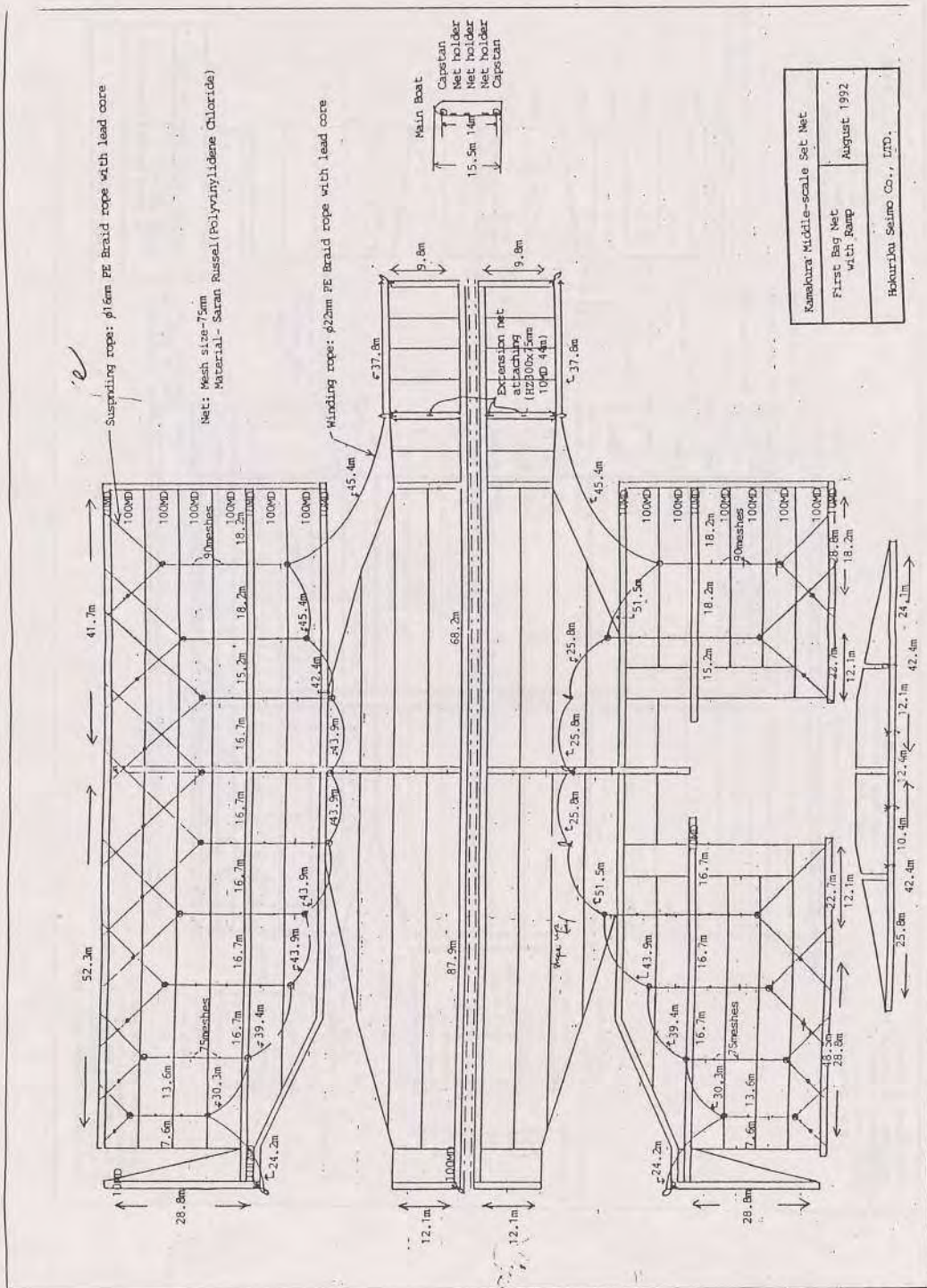

Appendix. 6

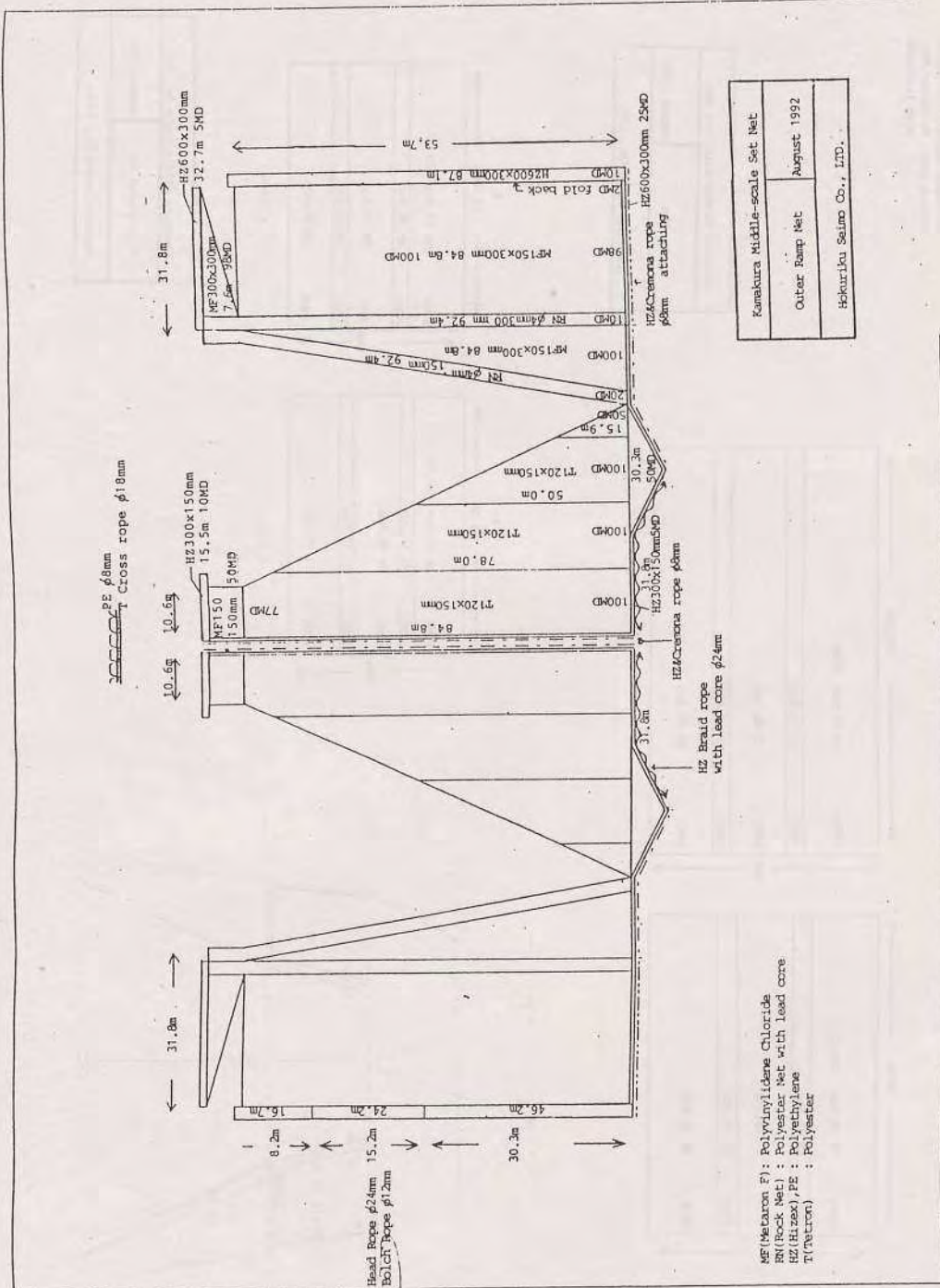



Appendix. 7

TR (Tetron Russel): Polyester  
 RN (Rock Net): Polyester Net  
 with lead core

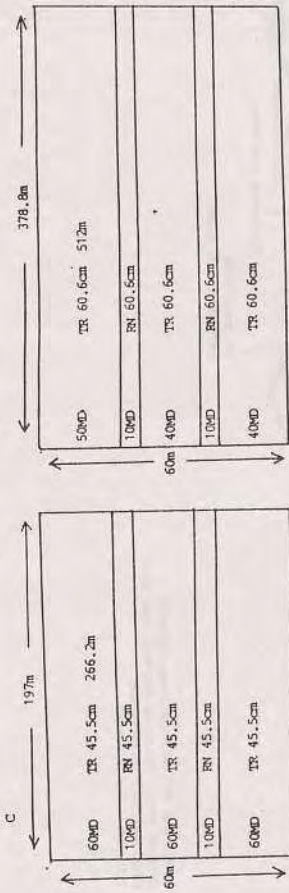

Kamakura Middle-scale Set Net	
Loader Net	August 1992
Hokuriku Seino Co., LTD.	

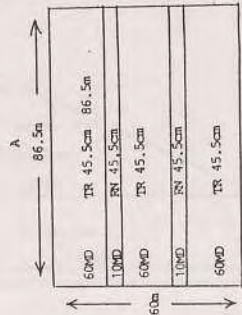

x 2pcs.

x 2pcs.

Kamakura Middle-scale Set Net	
Play Ground Net	August 1992
Hokuriku Seino Co., LTD.	

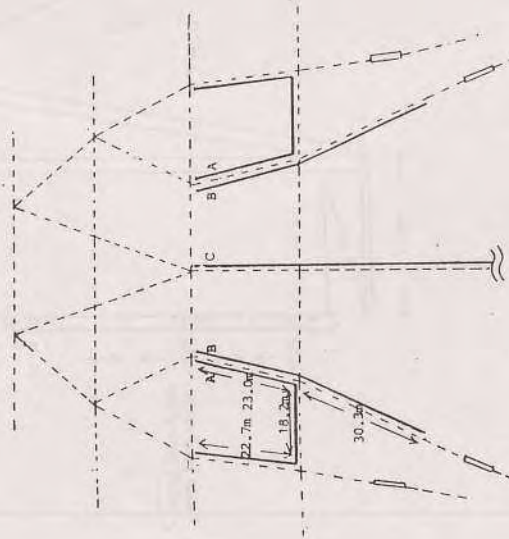

Appendix. 6

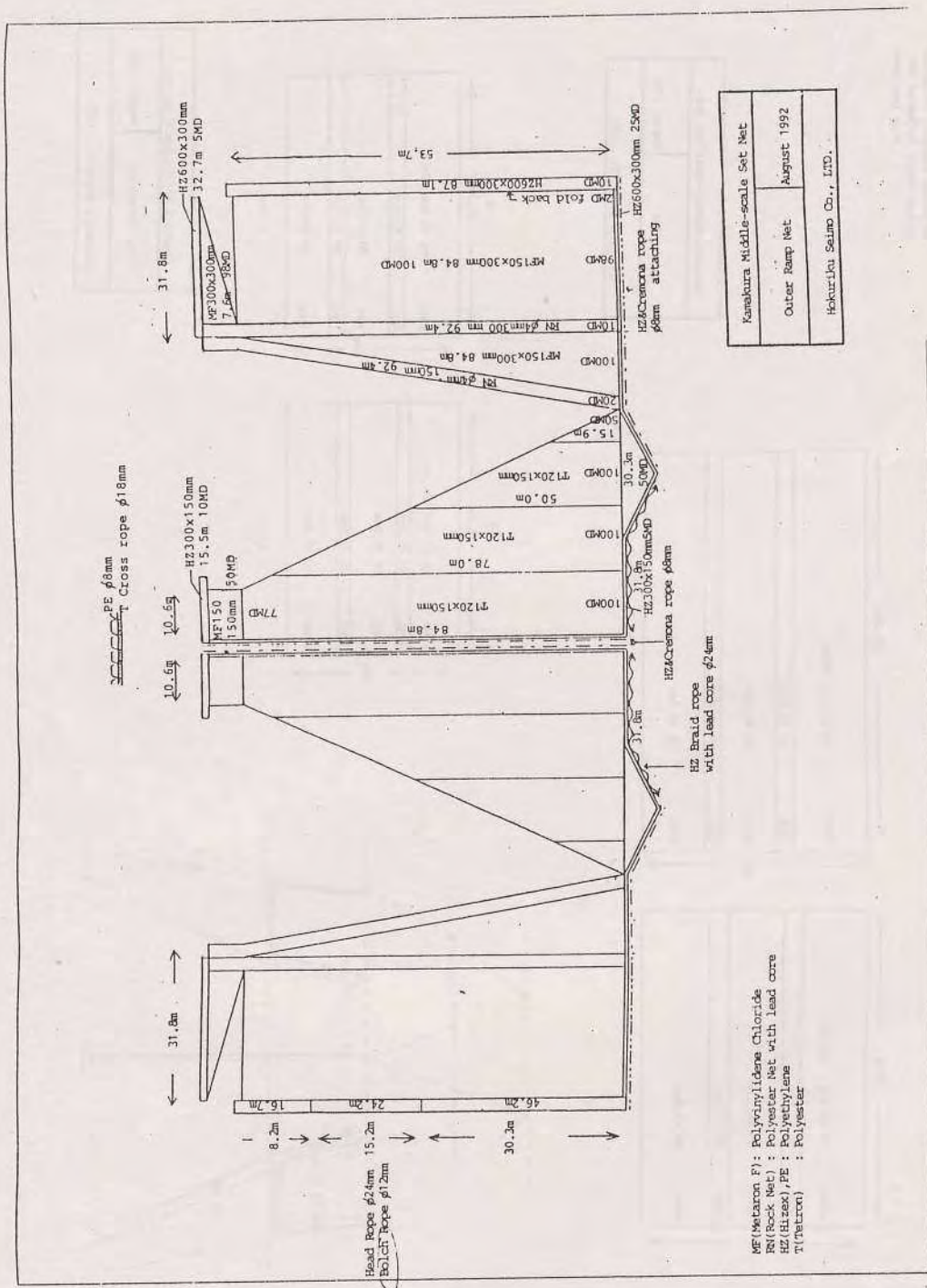

Kanokura Middle-scale Set Net	
Outer Ramp Net	August 1992
Hokuriku Seimo Co., LTD.	



Appendix. 7

TR(Tetron Russel): Polyester  
 RN(Rock Net): Polyester Net.  
 with lead core

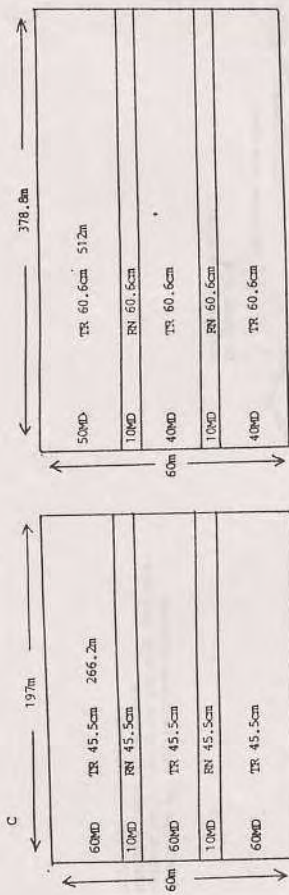

Kanakura Middle-scale Set Net	
Leader Net	August 1992
Hokuriku Seino Co., LTD.	

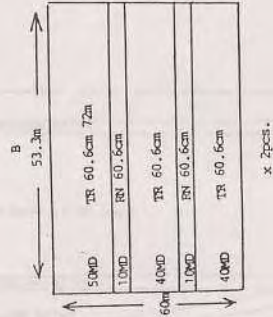
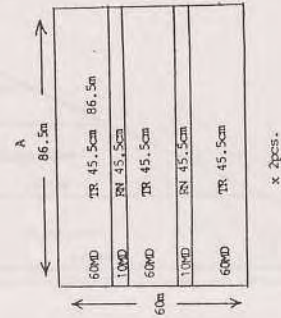

x 2pcs.

x 2pcs.

Kanakura Middle-scale Set Net	
Play Ground Net	August 1992
Hokuriku Seino Co., LTD.	

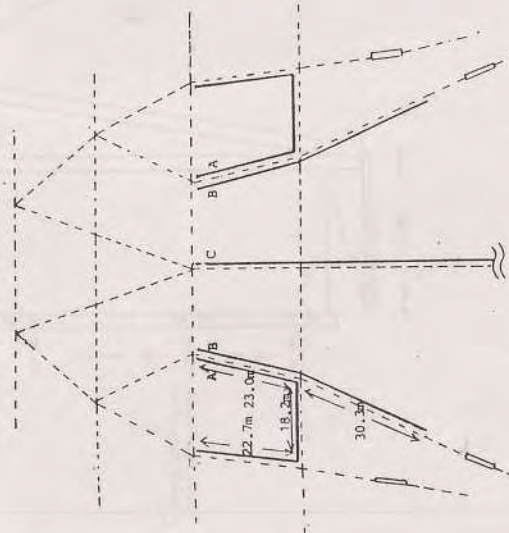

(有)井戸隠居丸鎌倉漁場

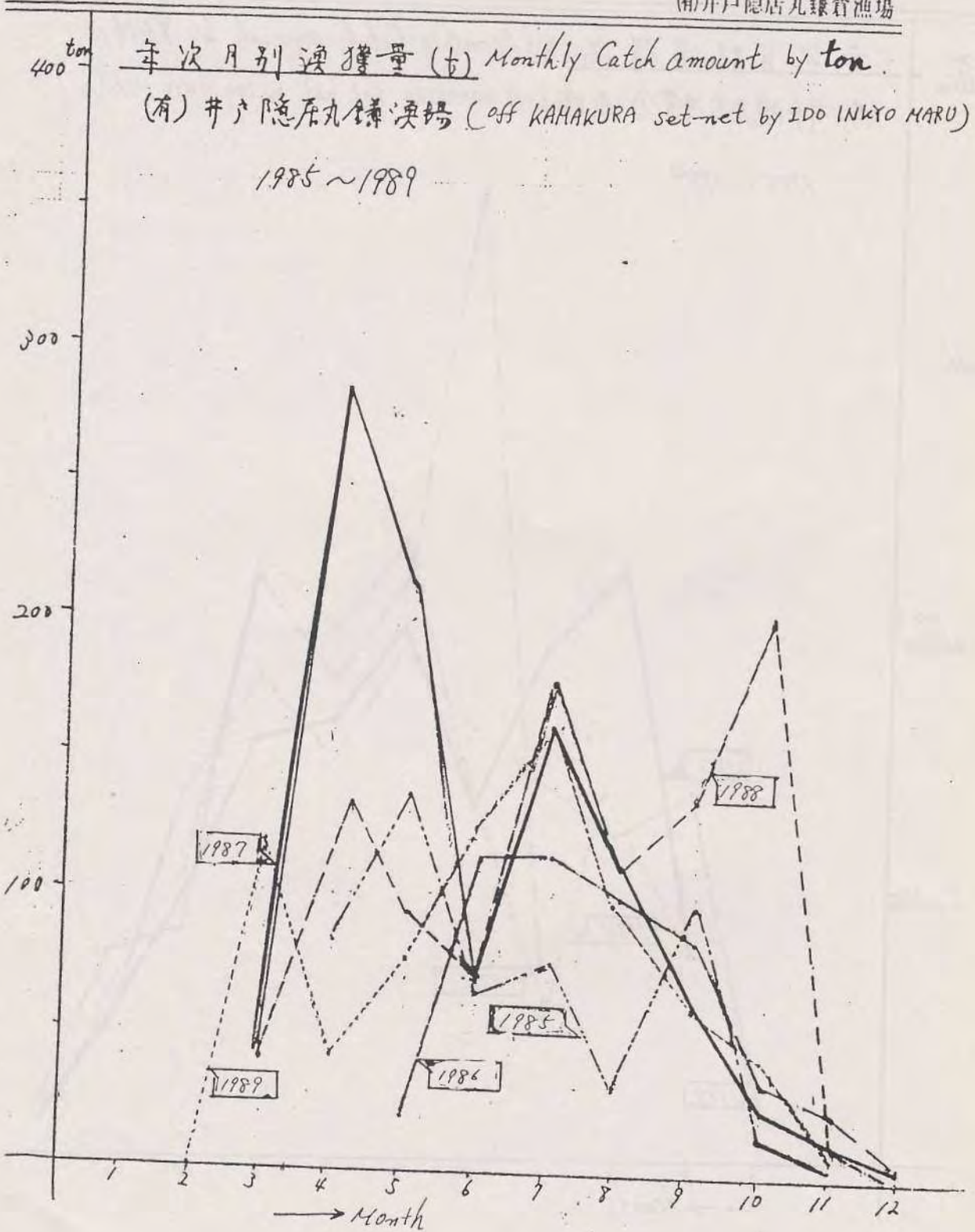



Appendix. 9

(有)井戸隠居丸鎌倉漁場

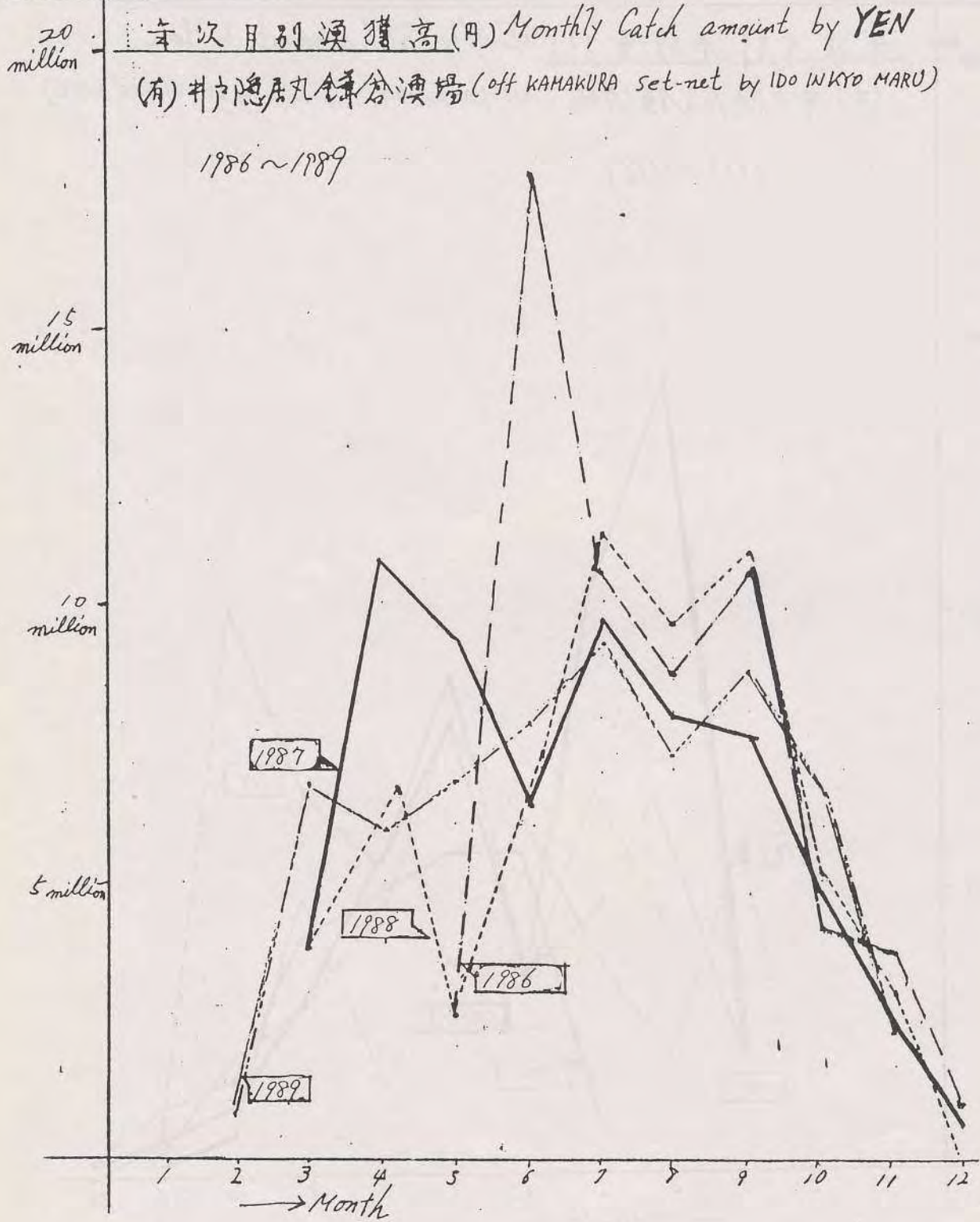

Appendix. 10

Annual Average Fish Price (Landing)  
(Kamakura Middle Scale Set-Net)

Unit : YEN

	1986	1987	1988	1989
Beak pesch	2,926	2,407	2,532	1,084
Horse mackerel	159	218	731	331
Barracuda	419	607	886	736
Hairtail (Cutlass fish)	868	953	550	352
Sardine	19.4	22.3	27.9	38.3
Young yellowtail	482	445	316	328
Mackerel	162	191	193	291
Squid	718	1,135	753	761
Spanish mackerel	734	795	750	941
Sea bream	2,391	1,366	2,221	2,558
Flounder	3,436	4,755	3,732	3,753
Sea bass	2,506	2,116	2,041	2,201
Young blue fin tuna	1,297	-	436	1,214
Dolphin (Dorado)	150	-	26	65
Frigate mackerel	47	73	62	47
Grunt	601	228	880	136
Puffer (Globe fish)	127	-	162	209
Amberjack	1,795	2,042	1,755	1,333
Total Average	119.8	63.8	71.7	85.1



1989 Kamakura Set-Net Summary  
(Middle Scale Set-Net)

1) Catch amount by Kg

Ranking	Fish kind	1989		1988	
		Quantity (kg)	Composition ratio	Quantity (kg)	Composition ratio
1	Sardine	627,191.20	85.5 %	809,561.90	82.5 %
2	Horse mackerel	25,288.90	3.5	4,830.72	0.5
3	Hairtail(cutlass)	23,902.20	3.3	11,151.20	1.1
4	Black scraper	17,600.92	2.4	66,439.70	6.8
5	Mackerel	9,845.70	1.4	26,410.90	2.7
6	Barracuda	3,829.15	0.5	6,877.30	0.7
7	Frigate mackerel	3,195.20	0.4	8,738.10	0.9
8	Grunt	3,110.75	0.4	950.50	-
9	Young yellowtail	2,316.60	0.3	25,927.70	2.6
	Others	16,862.83	2.3	21,087.40	2.2
	Total	733,143.43	100.0 %	982,005.40	100.0 %

2) Catch amount by YEN

Ranking	Fish kind	1989		1988	
		Quantity (YEN)	Composition ratio	Quantity (YEN)	Composition ratio
1	Sardine	Y 23,596,706	37.8 %	22,647,463	32.1 %
2	Hairtail	Y 8,427,241	13.5	6,141,745	8.7
3	Horse mackerel	Y 8,375,834	13.4	3,531,944	5.0
4	Sea bass	Y 3,687,843	5.9	3,574,059	5.1
5	Sea bream	Y 3,279,423	5.3	2,989,920	4.2
6	Mackerel	Y 2,870,834	4.6	5,110,499	7.3
7	Barracuda	Y 2,821,102	4.5	6,092,653	8.7
8	Young yellowtail	Y 759,718	1.3	8,206,073	11.6
	Others	Y 8,564,088	13.7	12,155,226	17.3
	Total	Y 62,382,789	100.0 %	70,449,582	100.0 %



1989 Summary of catch amount.  
平成元年産生量概況(1) 77

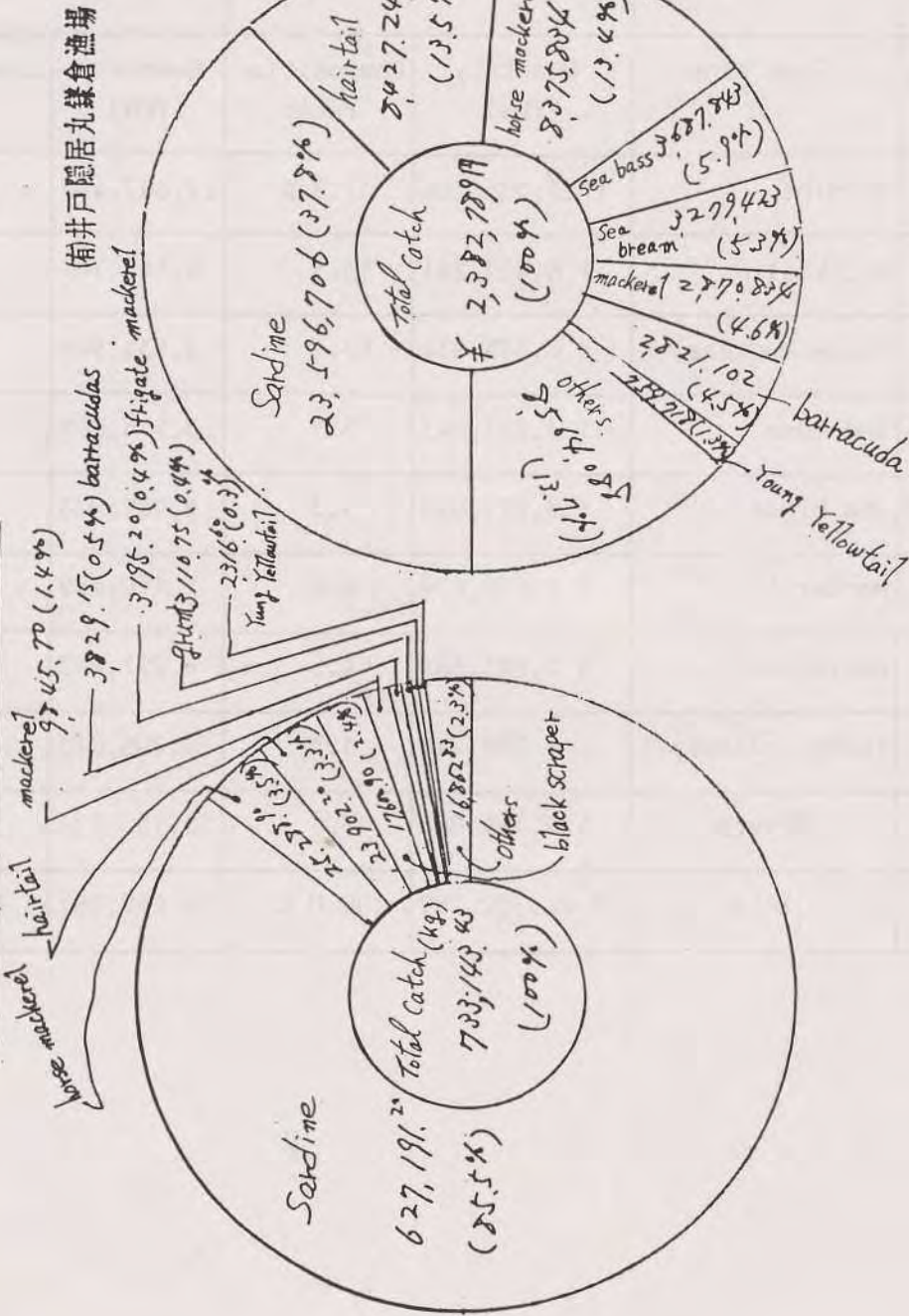

catch amount of principal fish kind, by TON  
 主要魚種別漁獲量

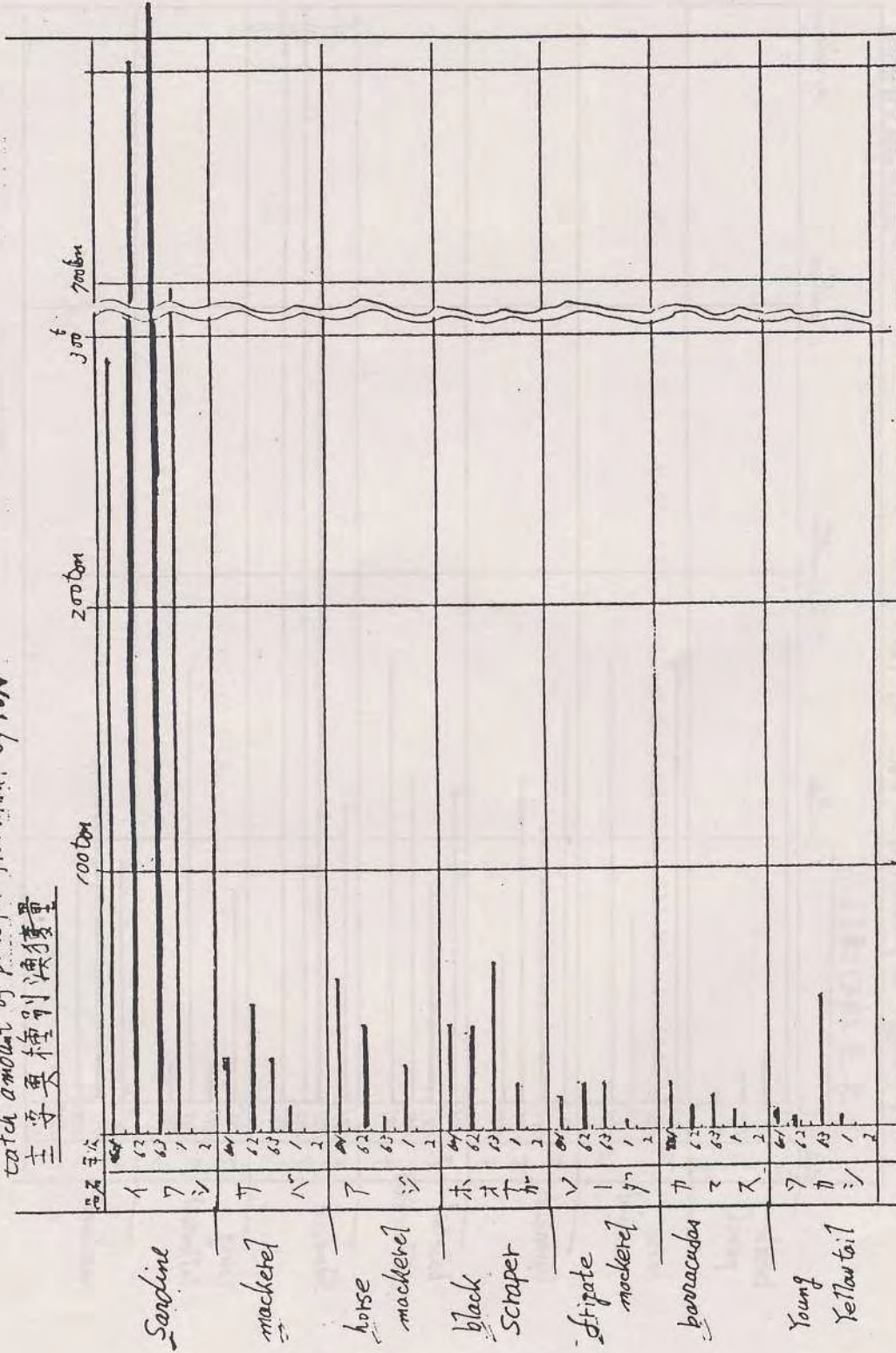

コ73 コ2-50 (64x44)



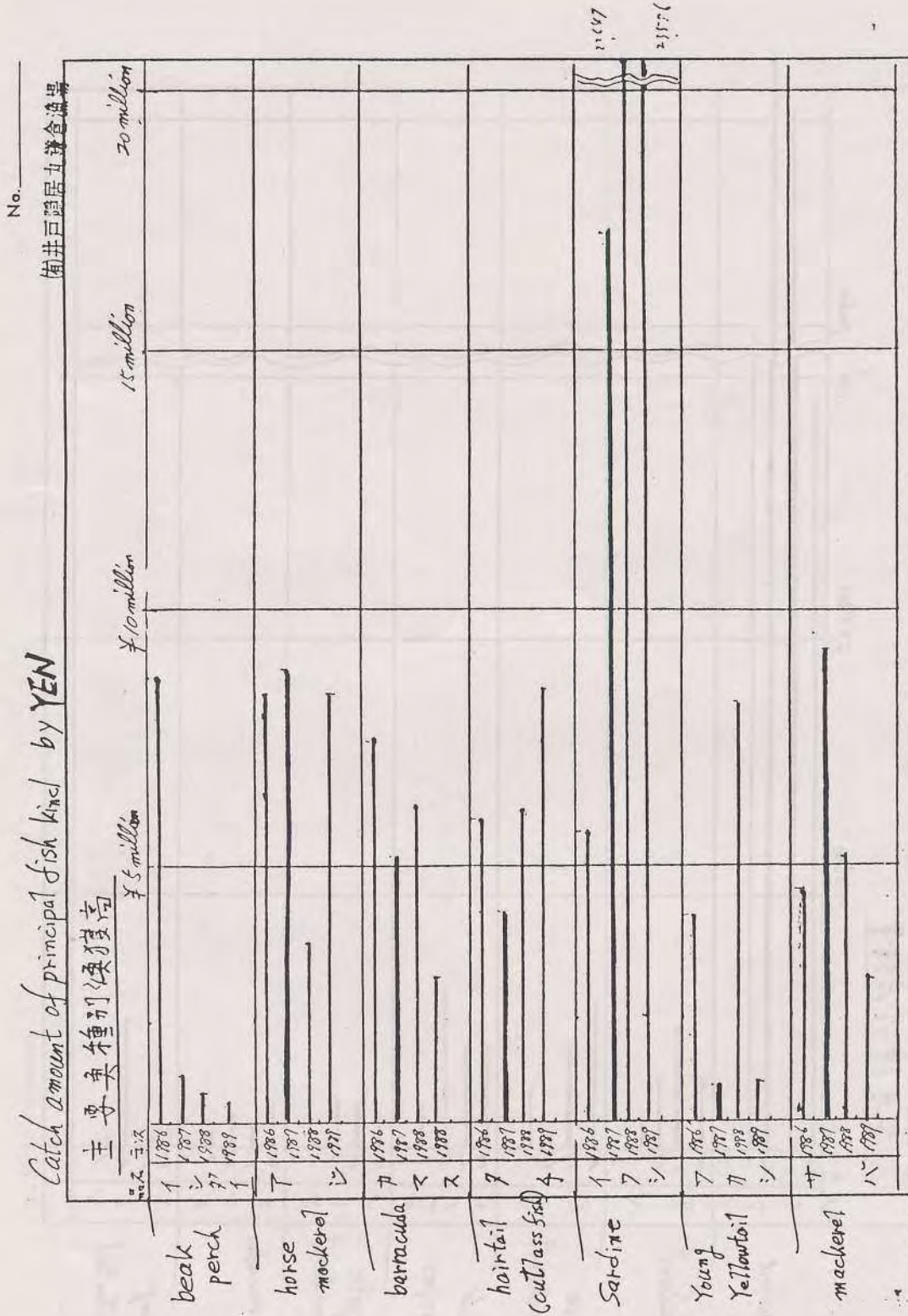

### Beam trawl fishing

- Date of study** : 6-7 April
- Fishing port** : Shiyasura port and Koshihira port  
(6 April) (7 April)
- Fishing boats** : Taki-maru and Tokushu-maru  
(6 April) (7 April)
- Fishing equipment** : 1) Three sets of stern winch, see Fig. 1  
2) Stern iron beam with pulley, see Fig. 3  
3) Navigation plotter with GPS and Loran C  
(on the Tokushu-maru), see Fig. 4  
4) Color-Echosounder
- Number of fishermen** : Two persons (one captain and one crew)
- Fishing gear construction:** 1) Iron beam, diameter 4 inch, length 6.5 m, weight 80 kg and ski, length 1.2 m, width 30 cm, weight 20 kg.  
2) Stainless chain, length 2 m, connected from the ski to the head rope and ground rope of the net.  
3) Head rope, length 13 m and Ground rope, weight 30 kg. On the ground rope, a round stainless plate with chain is attached. (See Fig. 7)  
4) Six-seam type of net construction which has two cod ends is used. (See Fig. 13)
- Fishing ground** : Tokyo Bay (mud bottom)



**Target catch** : Mantis shrimp

**Fishing method**

Shooting : 1) Winding rope which is attached to the ground rope will be connected with the rope from in front of the iron beam.

2) Cod end and net body are castled.

3) Iron beam is lifted up and towing warp is released from the connecting rope little by little; the length of the towing warp is seven times the depth.

Hauling : 1) Towing warp is rolled up by the stern winch until the iron beam and net are on the water surface.

2) The winding rope is released from the connecting rope and connected to the rope from the winch, then rolling starts. (See Fig. 2). The iron beam with ski is lifted and laid down on the stern deck.

3) The winding rope is rolled onto the winch until the ground rope is on the stern deck.

4) The cod end is lifted, then first cod end and second cod end are opened.

Remarks : The towing is for approximately 3.5 kts.

**Remark :** Five operations are always carried out in one day (day time operation only) and the catch depends on the rules of the fishery cooperative; for instance, one boat (two fishermen) is allowed a maximum catch/day of 250 packs of processed product.

- Fuel expenses are 120 lit/day, one lit = 40 yen  
(April '93)
- Cost of one boat 30,000,000 yen, including equipment
- Annual income is 20 million yen/boat.

### **Discussion**

According to the fishermen, the catch has increased from last year, with a 30% increase in catch compared to the last 3-5 years. Only the market size of mantis shrimp will be selected and non-market size released back to the sea. When the boat arrives at the port, the catch of mantis shrimp will be boiled, head-cut and packed.



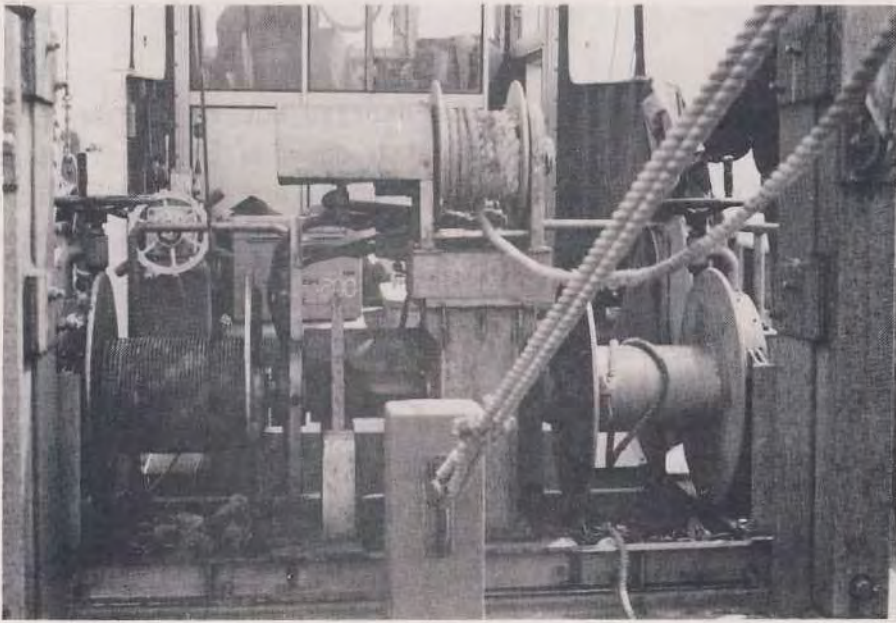

Fig. 1 Stern winch, consists of three winches.

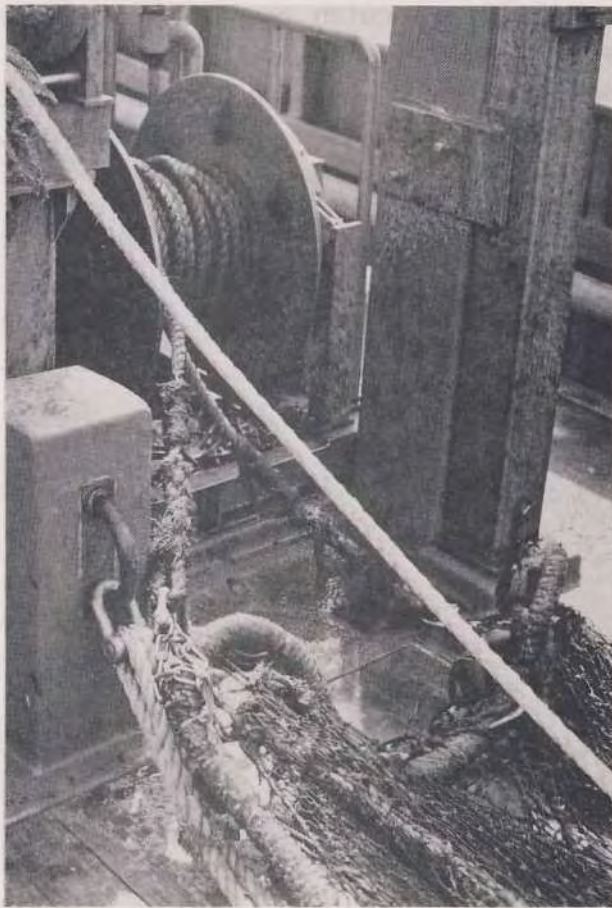

Fig. 2 One winch is used for rolling the winding rope.



Fig. 3 Stern iron beam with pulley.



Fig. 4 Navigation plotter on the fishing boat.





Figs. 5-6 Iron beam pipe with ski.



Fig. 7 Round-shape stainless plates with chains are attached to the front of the ground rope.



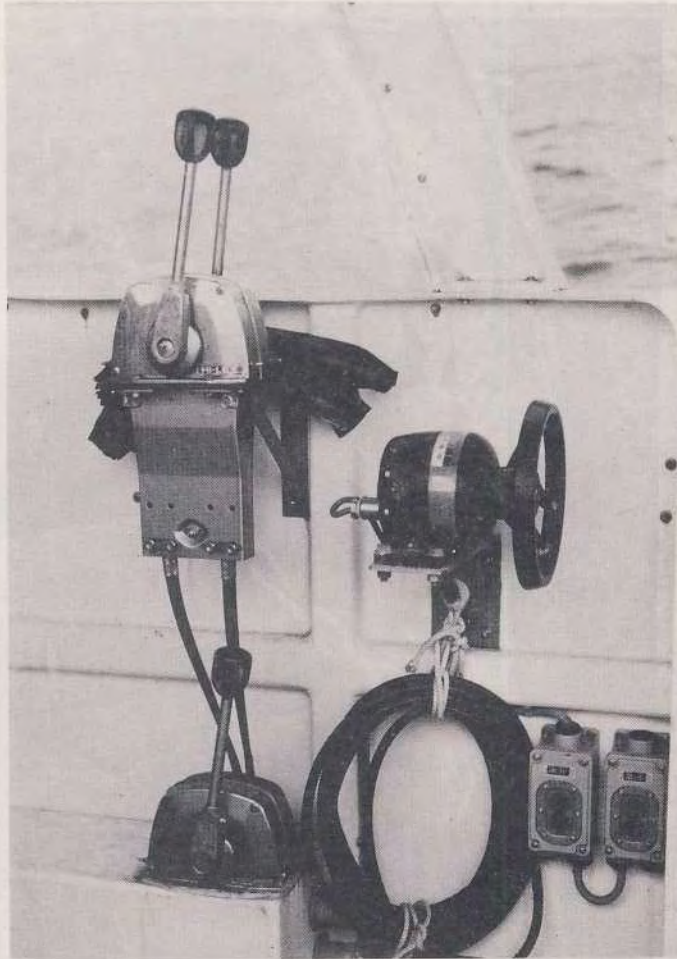
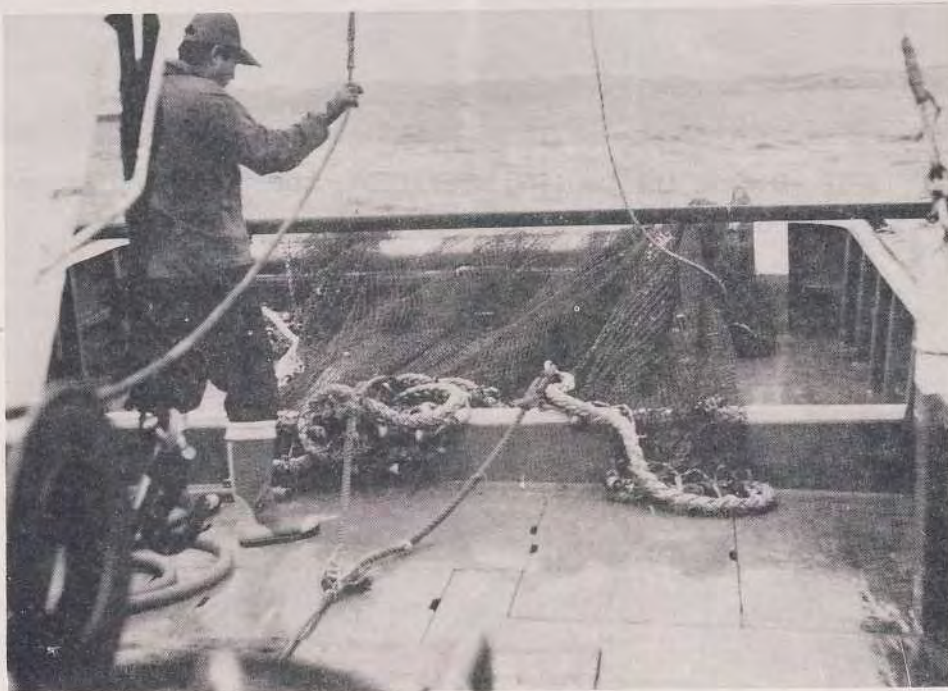

Fig. 8 Ship controller units are installed near the stern winch.



Figs. 9-10 During hauling operations, the winding rope is rolled onto the stern winch.





Figs. 11-12 During the hauling operation, the first and second cod end are opened.

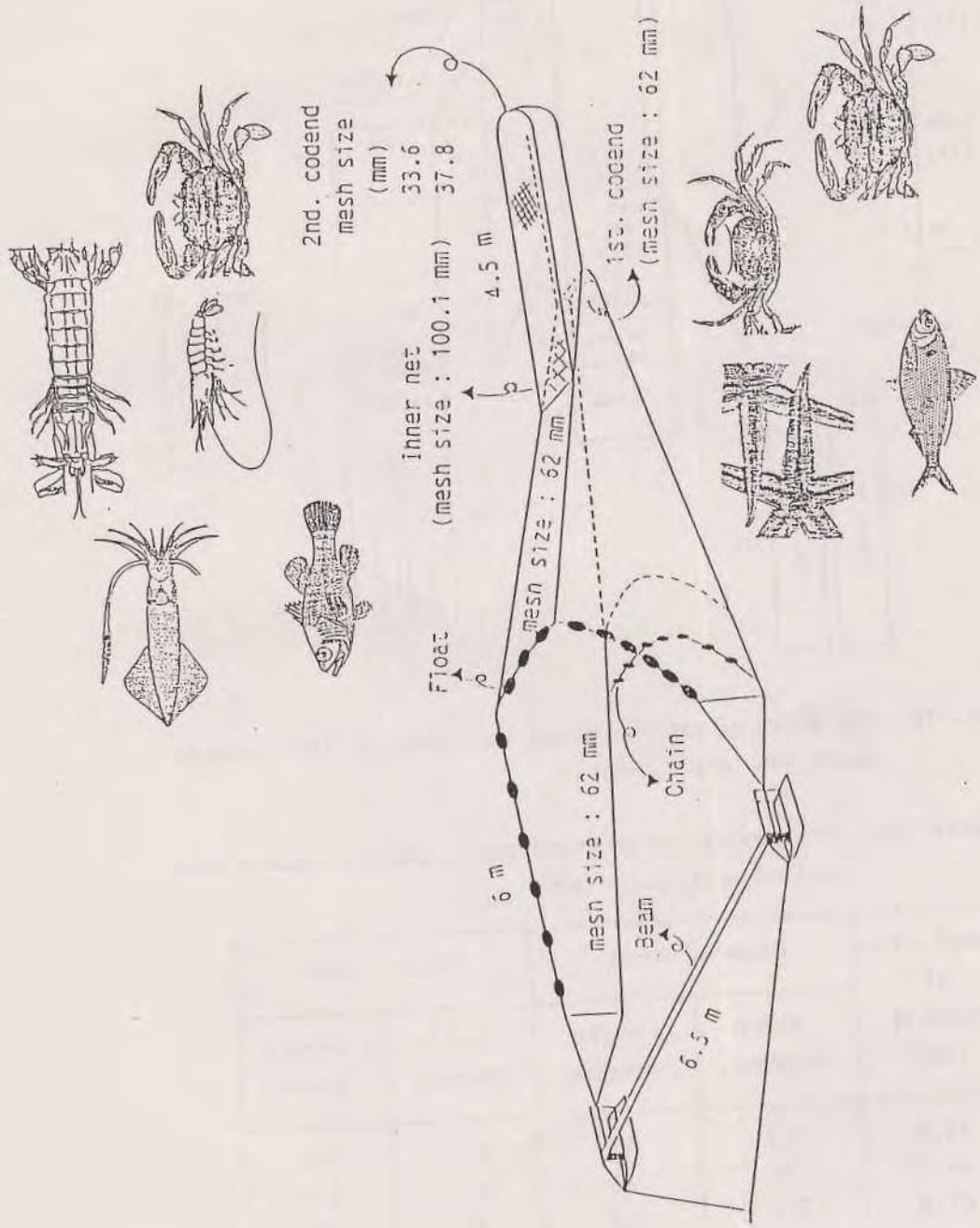

Fig. 13 The gear construction with two cod ends for catch selectivity.



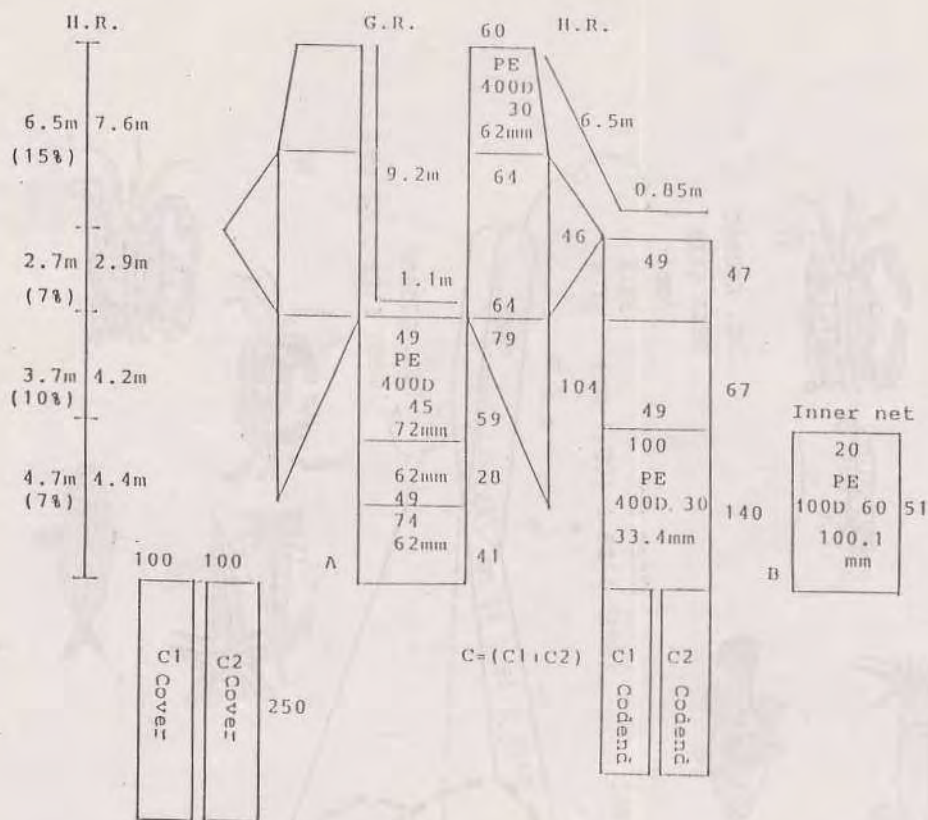

Fig. 14 Net plan of shrimp trawl net used in the trouser cover net experiment.

Table 2.1 The design of diamond mesh codend, square mesh codend and cover net.

Mesh size of codend (mm)	Diamond mesh		Square mesh	
	Width (Meshes)	Length (Meshes)	Width (Bars)	Length (Bars)
33.9	100	93	62	176
44.3	78	73	48	136
61.8	56	52	30	100
Cover net 18.4 mm	200	250	200	250

### Conger eel pot fishing

- Date of practice** : 10 April
- Fishing port** : Bunba
- Fishing boat** : Maruhashi-maru (3.2 tons, 230 ps), which engages in pot fishing, gill net fishing and surface pair-trawl fishing
- Fishing equipment** : A ball roller installed in the port side of fore deck
- Number of fisherman** : one person
- Fishing gear construction** : (Refer to Yamaha Fishery Journal, page 229)

The Hi-zex pipe cylindrical-type conger eel pot is made up of the following parts:

- 1) The cylinder: in order to attract the conger eel, which dislikes light, with a dark hole, black hi-zex is used for the cylinder. The pipe diameter is 15 cm. length 80 cm and thickness 8 mm. A number of small holes, 4 mm in diameter, are drilled in both ends of the cylinder to serve as water drainage holes and also to let out the smell of the bait.
- 2) Funnel: A funnel-shaped entrance, which allows the conger eel to enter the cylinder but prevent it from escape, is fitted to each end of the pipe. At first, the funnels were made of bamboo, later, however, an improved polyethylene one was developed.



- 3) **Sinker:** in order to provide the cylinder with stability on the sea bottom, two iron rods, diameter 9 mm, are attached to the cylinder by wires with a slight interval inbetween.
- 4) **Branch line:** A two-meter length of 4.5-6 mm diameter branch line is attached to the end of the cylinder to secure the pot to the main line.
- 5) **Main line:** An old tuna long line rope (vinyon) is used and the cylinders are attached to it at 25-45 meter intervals (depending on the water depth), with about 30-60 cylinders used on the length of a main line. A 3-5 tons fishing boat is used to operate three lines (a total of 100-180 pots) in one day.

#### Remarks

- One line of the main line, both ends are attached to the Octopus pot, instead of using sinkers. (See Fig. 5)
- There are three sizes of cylinder pot, large, medium and small, governed by the diameter of the pot. For instance, the medium cylinder pot can catch 6-7 pieces of conger eel in one time (the cost of cylinder and funnel are 1,280 and 280 yen/piece, respectively (as of March 1993); the cylinder can be used for 10 years.

**Fishing method :** A roller is used for lifting the line during operations. One or two sardines are put into the cylinder as bait before its is lowered to the sea bottom. After one day, the pot will be hauled up again, then the catch is removed and kept for one or two days to allow for the complete digestion of food in the intestines and the elimination of waste before the live conger eels are shipped to the market.

**Remark** : By Maruhashi-maru fishermen-they will not operate pot fishing in the same fishing ground and the direction of the gear is setting always from the west to the east. On the observation day, the fishing ground was located near Endoshima Island, Kamakura area. According to their experiences, the best fishing ground is the entrance of a river mouth.

**Discussion** : The cylinder pot fishing seasons are from January - May and June - October. In the summer season it is difficult to keep the conger eels alive. The price of the conger eels in January - May and June - October is approximately 1,500 - 2,000 yen and 500-800 yen, respectively, with the average catch range 50-60 kg/one operation. (March '93).



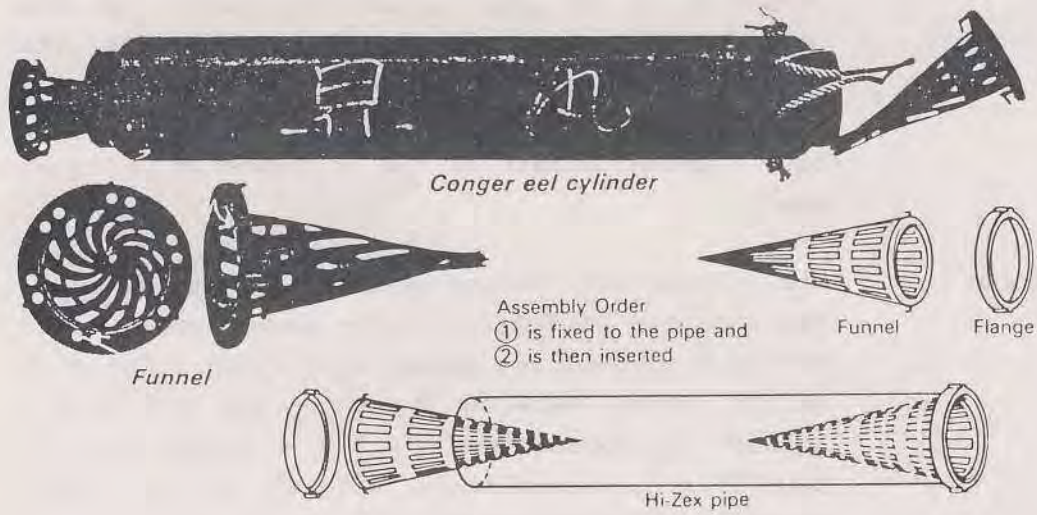
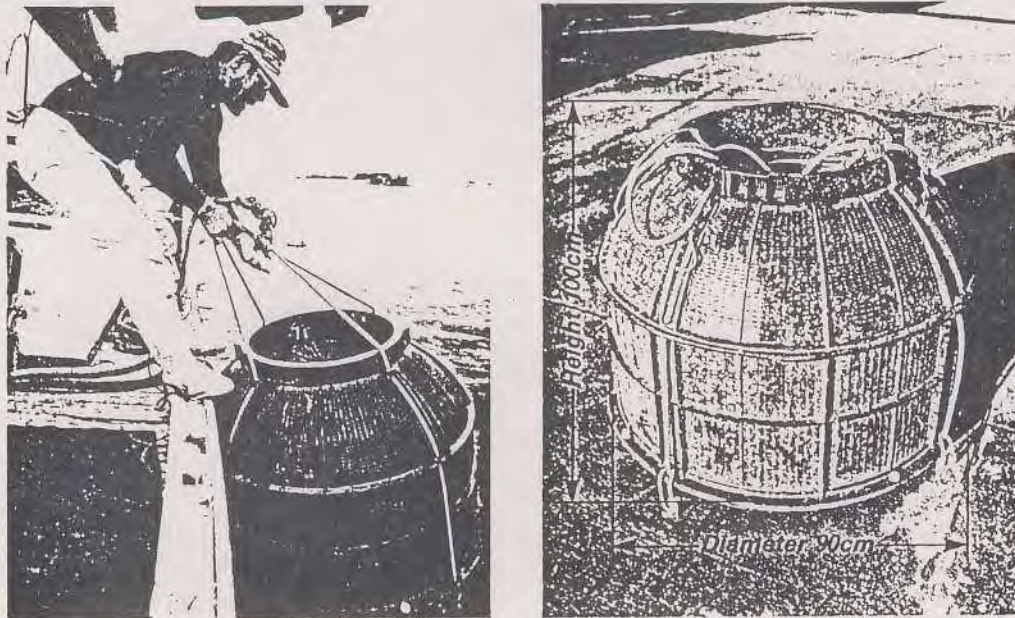

Fig. 1 The conger eel pot fishing gear construction



A preserve tank for keeping live conger eels

Fig. 2 Preserve tank for live conger eel before sale





Fig. 3 Port-side ball roller



Fig. 4 Ball roller controller and ship controller position conveniently located for one operation.



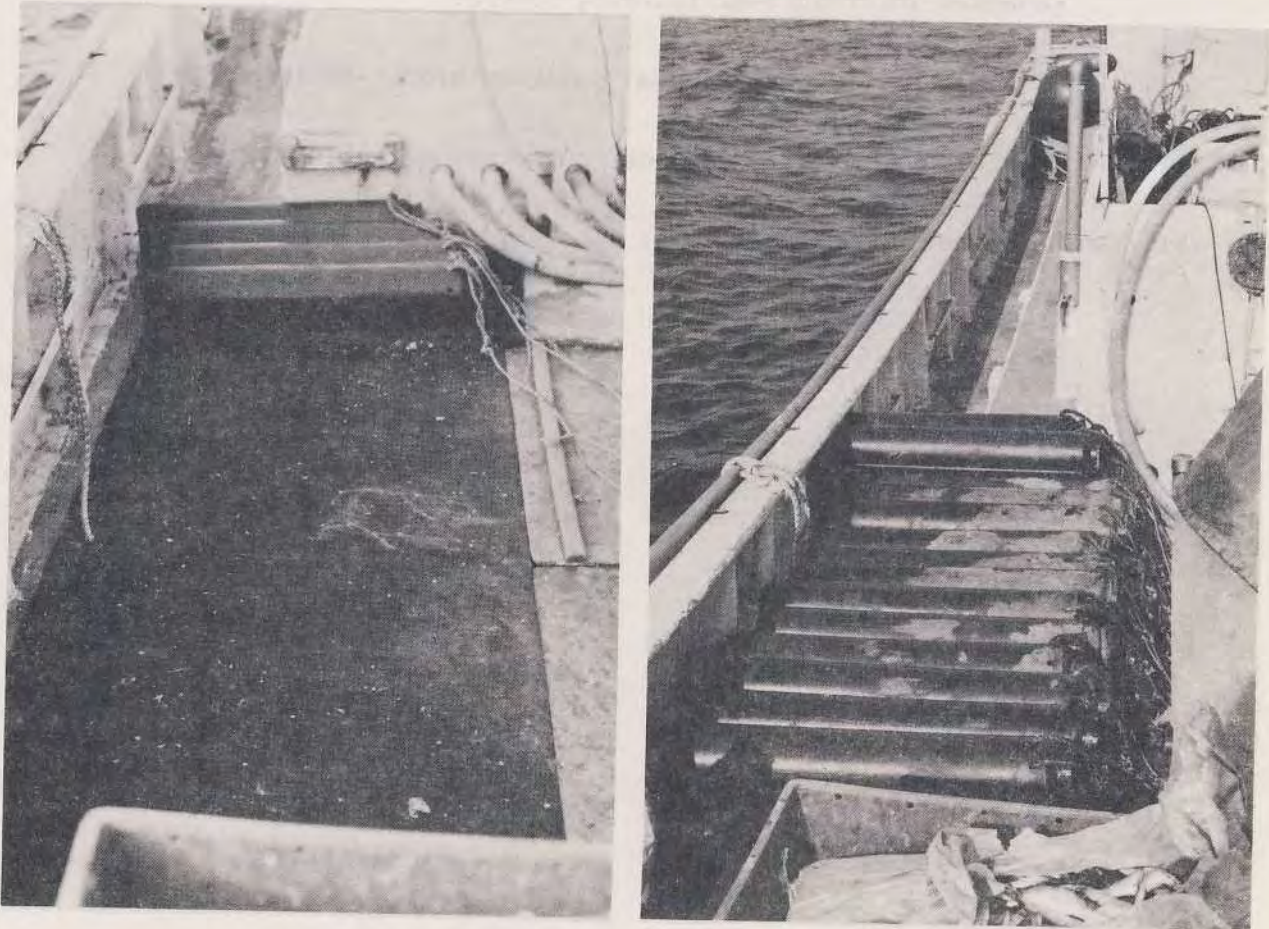

Fig. 5 An octopus pot is used instead of sinker weight.



Fig. 6 Hauling operation.





Figs. 7-8 Arranging of the pots during hauling operation.





### References

- 1) F. Motoki, 1992, Deep Sea Crab & Shrimp Basket Fishing in Nagai.
- 2) G. Gustavo and V. Olivelia, 1993, Study report on pot fishing, Kanagawa International Training Centre.
- 3) KIFTC, 1993, Statistical data on Kamakura middle-scale set net.
- 4) Nichimo Co., Ltd., 1993, One boat purse seine fishing.
- 5) Yamaha Fisheries Journal.

